



## Galvenā

Produkta sērija	Altivar Machine ATV340
Produkta vai sastāvdaļas veids	Variable speed drive
Produkta specifiskais pielietojums	Machine
Variants	Standard version
Montāžas veids	Wall mount
Komunikācijas porta protokols	Modbus TCP Modbus serial Ethernet/IP
Option card	Communication module, Profinet Communication module, DeviceNet Communication module, CANopen Communication module, EtherCAT
Tīkla fāžu skaits	3 fāzes
Supply frequency	50...60 Hz +/- 5 %
[Us] rated supply voltage	380...480 V - 15...10 %
Nominal output current	88,0 A
Motor power kW	55 KW normal duty 45 kW heavy duty
Motor power hp	75 Hp normal duty 60 hp heavy duty
EMC filter	Class C3 EMC filter integrated
IP degree of protection	IP20
Degree of protection	UL type 1

## Papildinošs

Discrete input number	8
Discrete input type	PTI safe torque off 0...30 kHz, 24 V DC 30 V) DI1...DI5 programmable as pulse input, 24 V DC 30 V)3.5 kOhm programmable
Number of preset speeds	16 preset speeds
Discrete output number	1,0
Discrete output type	Programmable output DQ1, DQ2 30 V DC 100 mA
Analogue input number	3
Analogue input type	A11 software-configurable current 0...20 mA 250 Ohm 12 bits A11 software-configurable temperature probe or water level sensor A11 software-configurable voltage 0...10 V DC 31.5 kOhm 12 bits A12 software-configurable voltage - 10...10 V DC 31.5 kOhm 12 bits
Analogue output number	2
Analogue output type	Software-configurable voltage AQ1, AQ2 0...10 V DC 470 Ohm 10 bits Software-configurable current AQ1, AQ2 0...20 mA 500 Ohm 10 bits
Relay output number	3
Izvada spriegums	<= power supply voltage
Relay output type	Relay outputs R1A Relay outputs R1C 100000 cikli Relay outputs R2A Relay outputs R2C 100000 cikli

The information provided in this documentation contains general descriptions and/or technical characteristics of the performance of the products contained herein. This documentation is not intended as a substitute for and is not to be used for determining suitability or reliability of these products for specific user applications. It is the duty of any such user or integrator to perform the appropriate and complete risk analysis, evaluation and testing of the products with respect to the relevant specific application or use thereof. Neither Schneider Electric Industries SAS nor any of its affiliates or subsidiaries shall be responsible or liable for misuse of the information contained herein.

Maximum switching current	Relay output R1C pretestības, cos phi = 1 3 A 250 V AC Relay output R1C pretestības, cos phi = 1 3 A 30 V DC Relay output R1C induktīvs, cos phi = 0,4 7 ms 2 A 250 V AC Relay output R1C induktīvs, cos phi = 0,4 7 ms 2 A 30 V DC Relay output R2C pretestības, cos phi = 1 5 A 250 V AC Relay output R2C pretestības, cos phi = 1 5 A 30 V DC Relay output R2C induktīvs, cos phi = 0,4 7 ms 2 A 250 V AC Relay output R2C induktīvs, cos phi = 0,4 7 ms 2 A 30 V DC
Minimum switching current	Relay output R1B 5 mA 24 V DC Relay output R2C 5 mA 24 V DC
Fiziskais "interfeiss"	2-wire RS 485
Konektora tips	3 RJ45
Method of access	Slave Modbus RTU Slave Modbus TCP
Pārraides ātrums	4.8 kbit/s 9.6 kbit/s 19.2 kbit/s 38.4 kbit/s
Transmission frame	RTU
Adrešu skaits	1...247
Data format	8 bits, configurable odd, even or no parity
Type of polarization	No impedance
4 quadrant operation possible	"True"
Asynchronous motor control profile	Constant torque standard Optimized torque mode Variable torque standard
Synchronous motor control profile	Reluctance motor Permanent magnet motor
Pollution degree	2 IEC 61800-5-1
Maximum output frequency	0,599 kHz
Acceleration and deceleration ramps	S, U or customized Linear adjustable separately from 0.01...9999 s
Motor slip compensation	Not available in permanent magnet motor law Can be suppressed Adjustable Automatic whatever the load
Switching frequency	1...8 kHz adjustable 2.5...8 kHz with derating factor
Nominal switching frequency	2.5 kHz
Braking to standstill	By DC injection
Brake chopper integrated	"True"
Line current	97,2 A 380 V normal duty) 84,2 A 480 V normal duty) 81,4 A 380 V heavy duty) 71,8 A 480 V heavy duty)
Line current	97,2 A 380 V with internal line choke normal duty) 84,2 A 480 V with internal line choke normal duty) 81,4 A 380 V with internal line choke heavy duty) 71,8 A 480 V with internal line choke heavy duty) 81,4 A 71,8 A
Maksimālā ieejas strāva	97,2 A
Maximum output voltage	480 V
Apparent power	70 KVA 480 V normal duty) 59,7 kVA 480 V heavy duty)
Maximum transient current	127,2 A 60 s normal duty) 132 A 60 s heavy duty) 127,2 A 2 s normal duty) 132 A 2 s heavy duty)
Electrical connection	Skrūvju spaile 0.75...1.5 mm <sup>2</sup> control Skrūvju spaile 70...120 mm <sup>2</sup> line side Skrūvju spaile 70...120 mm <sup>2</sup> DC bus Skrūvju spaile 70...120 mm <sup>2</sup> motor
Prospective line I <sub>sc</sub>	50 kA
Base load current at high overload	88,0 A
Base load current at low overload	106,0 A

Power dissipation in W	Natural convection 105 W 380 V 4 kHz heavy duty) Forced convection 943 W 380 V 4 kHz heavy duty) Natural convection 115 W 380 V 4 kHz normal duty) Forced convection 917 W 380 V 4 kHz normal duty)
Electrical connection	Control skrūvju spaile 0.75...1.5 mm <sup>2</sup> AWG 18...AWG 16 Line side skrūvju spaile 70...120 mm <sup>2</sup> AWG 1/0...250 kcmil DC bus skrūvju spaile 70...120 mm <sup>2</sup> AWG 1/0...250 kcmil Motor skrūvju spaile 70...120 mm <sup>2</sup> AWG 1/0...250 kcmil
With safety function Safely Limited Speed (SLS)	"True"
With safety function Safe brake management (SBC/SBT)	"True"
With safety function Safe Operating Stop (SOS)	False
With safety function Safe Position (SP)	False
With safety function Safe programmable logic	False
With safety function Safe Speed Monitor (SSM)	False
With safety function Safe Stop 1 (SS1)	"True"
With sft fct Safe Stop 2 (SS2)	False
With safety function Safe torque off (STO)	"True"
With safety function Safely Limited Position (SLP)	False
With safety function Safe Direction (SDI)	False
Protection type	Termiskā aizsardzība motor Safe torque off motor Motor phase loss motor Termiskā aizsardzība drive Safe torque off drive Pārkaršana drive Overcurrent drive Output overcurrent between motor phase and earth drive Output overcurrent between motor phases drive Short-circuit between motor phase and earth drive Short-circuit between motor phases drive Motor phase loss drive DC Bus overvoltage drive Line supply overvoltage drive Line supply undervoltage drive Input supply loss drive Exceeding limit speed drive Break on the control circuit drive
Platums	271,0 mm
Augstums	908,0 mm
Dzīļums	309,0 mm
Neto svars	56,4 kg
Continuous output current	106 A 4 kHz normal duty 88 A 4 kHz heavy duty

## Vide

Operating altitude	<= 4800 m with current derating above 1000m
Operating position	Vertical +/- 10 degree
Produkta sertifikācija	UL[RETURN]CSA[RETURN]TÜV[RETURN]EAC[RETURN]CTick
Marķējums	CE
Standarti	IEC 61800-3 IEC 61800-5-1 IEC 60721-3 IEC 61508 IEC 13849-1 UL 618000-5-1 UL 508C IEC 61000-3-12
Maximum THDI	<48 % pilna slodze IEC 61000-3-12 <48 % 80 % load IEC 61000-3-12
Assembly style	With heat sink
Electromagnetic compatibility	Electrostatic discharge immunity test level 3 IEC 61000-4-2 Radiated radio-frequency electromagnetic field immunity test level 3 IEC 61000-4-3 Electrical fast transient/burst immunity test level 4 IEC 61000-4-4 1.2/50 µs - 8/20 µs surge immunity test level 3 IEC 61000-4-5 Conducted radio-frequency immunity test level 3 IEC 61000-4-6

Environmental class (during operation)	Class 3C3 according to IEC 60721-3-3 Class 3S3 according to IEC 60721-3-3
Maximum acceleration under shock impact (during operation)	150 m/s <sup>2</sup> at 11 ms
Maximum acceleration under vibrational stress (during operation)	10 m/s <sup>2</sup> at 13...200 Hz
Maximum deflection under vibratory load (during operation)	1.5 mm at 2...13 Hz
Permitted relative humidity (during operation)	Class 3K5 according to EN 60721-3
Volume of cooling air	295,0 m <sup>3</sup> /h
Type of cooling	Forced convection
Pārsprieguma kategorija	Class III
Regulation loop	Adjustable PID regulator
Noise level	62,4 dB
Piesārņojuma pakāpe	2
Ambient air transport temperature	-40...70 °C
Ambient air temperature for operation	-15...50 °C without derating vertical position) 50...60 °C with derating factor vertical position)
Apkārtējā gaisa temperatūra uzglabāšanai	-40...70 °C
Izolācija	Between power and control terminals

### Iepakojšanas vienības

Pirmā iepakojuma vienības tips	PCE
Vienību skaits 1. iepakojumā	1
1. iepakojuma augstums	60 cm
1. iepakojuma platums	43 cm
1. iepakojuma garums	111 cm
1. iepakojuma svars	66 kg

### Piedāvājiem ilgtspēju

Ilgtspējīgs piedāvājuma statuss	Green Premium izstrādājums
REACH regula	<a href="#">REACH Deklarācija</a>
ES RoHS direktīva	Proaktīva atbilstība (uz izstrādājumu neattiecas ES RoHS juridiskās saistības)
Ķīnas RoHS regula	<a href="#">Ķīnas RoHS Deklarācija</a>
Informācija par RoHS izņēmumiem	<a href="#">Jā</a>
Vides informācijas publiskošana	<a href="#">Produkta Ietekme Uz Vidi</a>
Cirkularitātes profils	<a href="#">Informācija Par Eksploatācijas Izbeigšanu</a>
WEEE	Eiropas Savienības tirgū no šī produkta ir jāatbrīvojas, ievērojot noteiktu atkritumu savākšanas kārtību, un produkts nedrīkst nonākt sadzīves atkritumu tvertnēs.
Atjaunināšanas iespējas	Pieejamas atjauninātas komponentes

---

Dimensions

---

Views: Front - Left - Rear

mm  
in

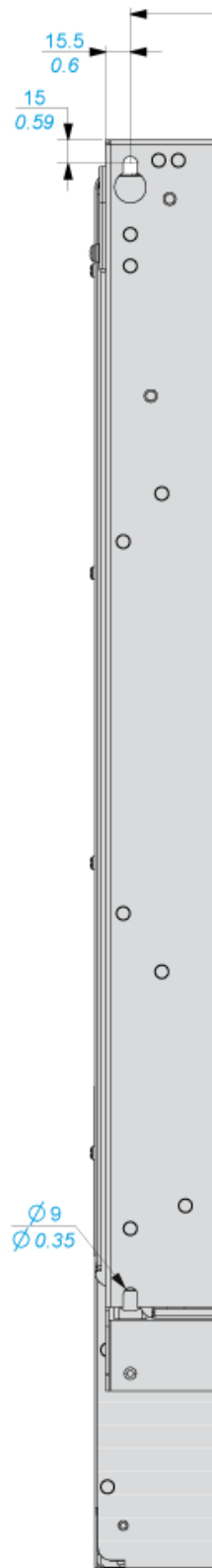
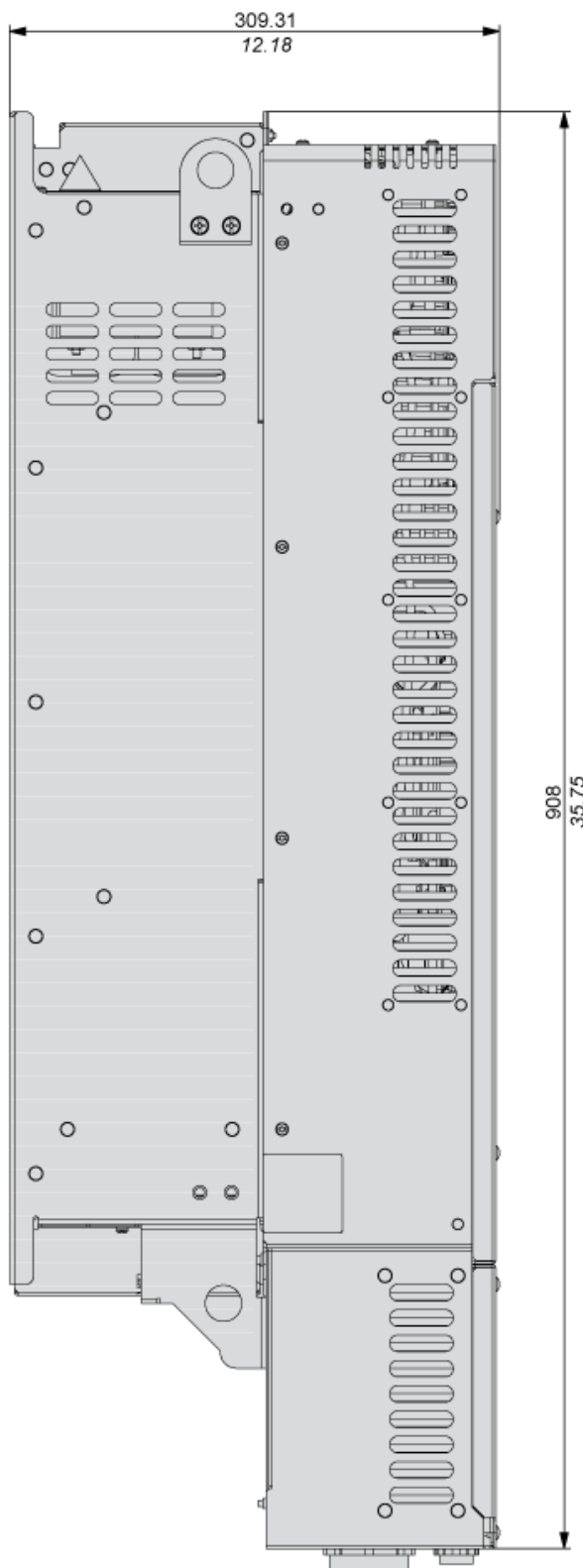
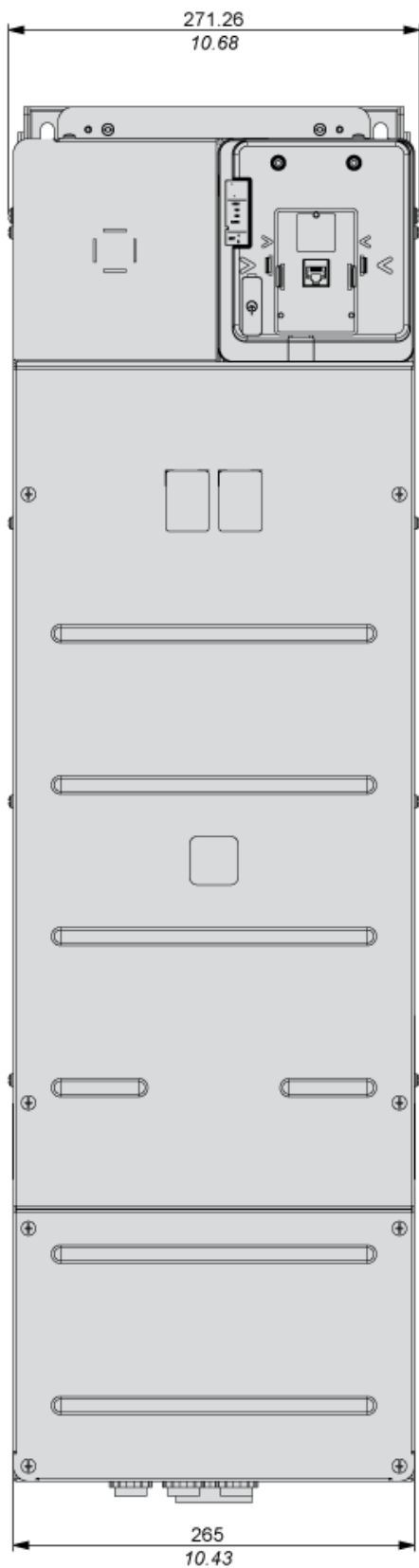

Clearance

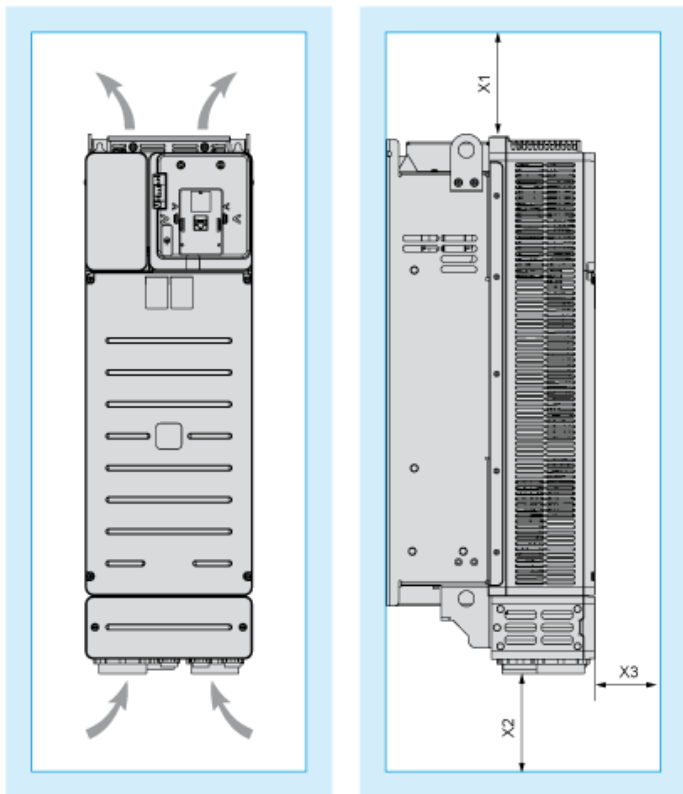

Dimensions in mm

X1	X2	X3
≥ 100	≥ 100	≥ 10

Dimensions in in.

X1	X2	X3
≥ 3.94	≥ 3.94	≥ 0.39

Mounting Types

Mounting Type A: Side by Side IP20

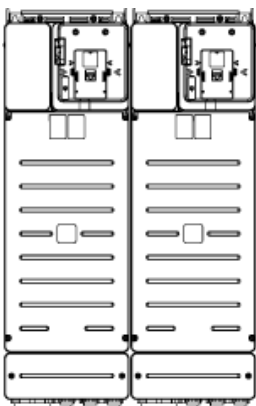

Possible, up to 50 °C, 2 drives only

### Mounting Type B: Individual IP20

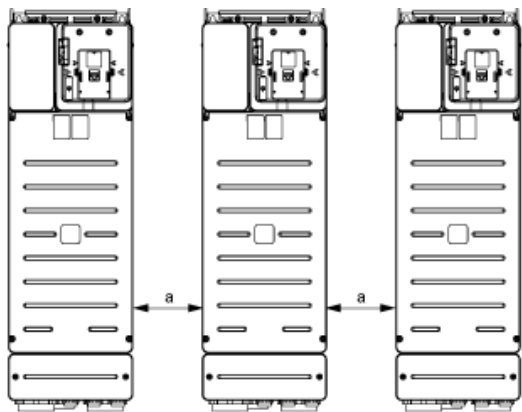

$a \geq 110 \text{ mm (4.33 in.)}$



Connections and Schema

Three-Phase Power Supply with Upstream Breaking via Line Contactor Without Safety Function STO

Connection diagrams conforming to standards ISO13849 category 1 and IEC/EN 61508 capacitySIL1, stopping category 0 in accordance with standard IEC/EN 60204-1.

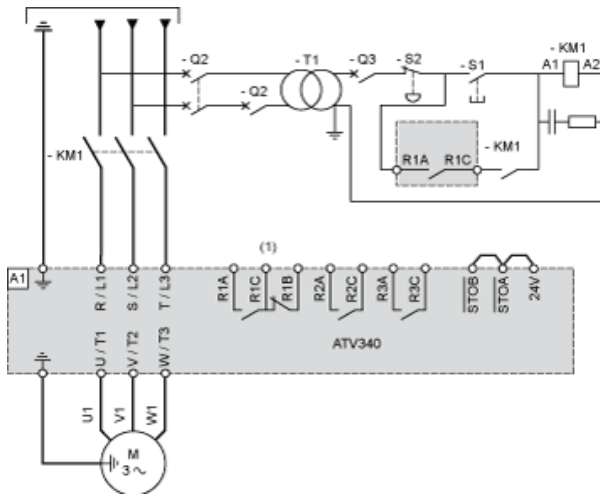

(1) Use relay output R1 set to operating state Fault to switch Off the product once an error is detected.

A1 : Drive

KM1 Line Contactor

Q2, Circuit breakers

Q3 :

S1 : Pushbutton

S2 : Emergency stop

T1 : Transformer for control part

Three-Phase Power Supply with Downstream Breaking via Switch Disconnecter

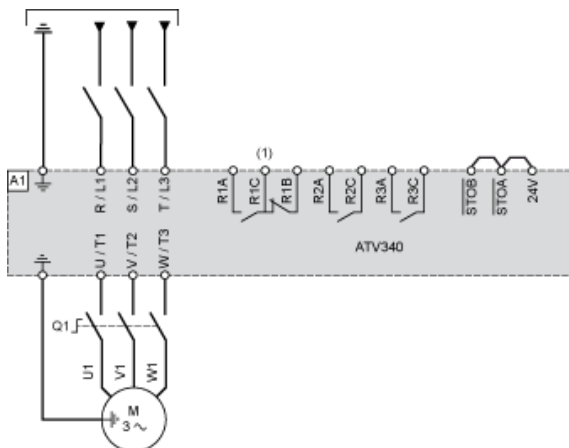

(1) Use relay output R1 set to operating state Fault to switch Off the product once an error is detected.

A1 : Drive

Q1 : Switch disconnecter

## Sensor Connection

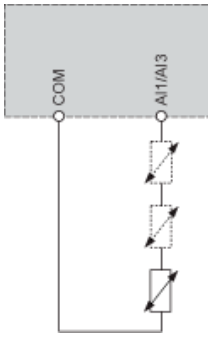

It is possible to connect either 1 or 3 sensors on terminals AI1/AI3.

## Control Block Wiring Diagram

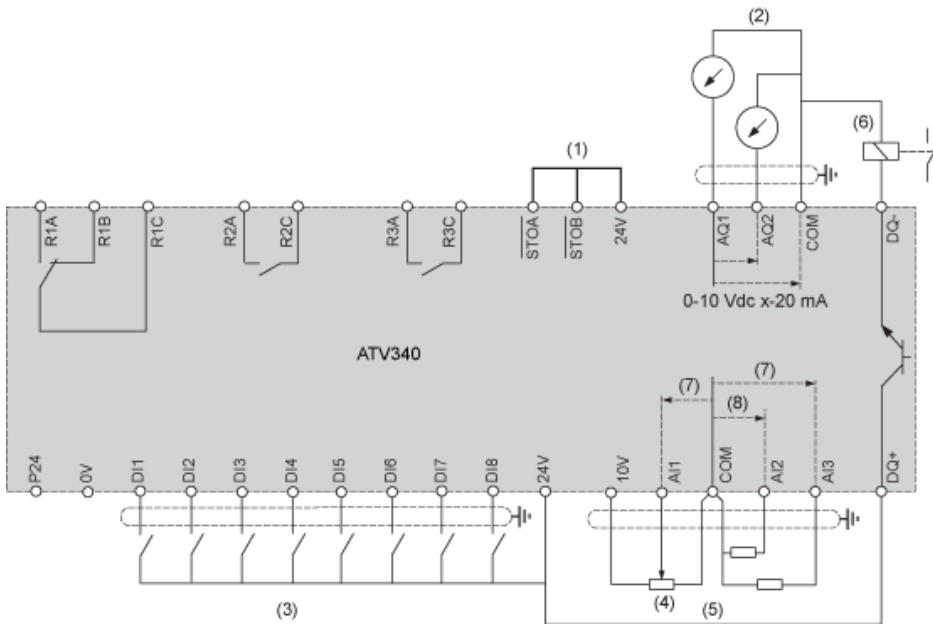

- (1) Safe Torque Off
  - (2) Analog Output
  - (3) Digital Input
  - (4) Reference potentiometer
  - (5) Analog Input
  - (6) Digital Output
  - (7) 0-10 Vdc, x-20 mA
  - (8) 0-10 Vdc, -10 Vdc...+10 Vdc
- A1 : ATV340 Drive  
 R1A, Fault relay  
 R1B,  
 R1C :  
 R2A, Sequence relay  
 R2C :  
 R3A, Sequence relay  
 R3C :

## Digital Inputs Wiring

Switch Set to SRC (Source) Position Using the Output Power Supply for the Digital Inputs

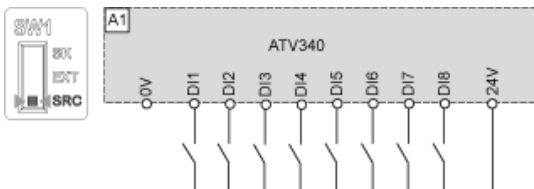

### Switch Set to SRC (Source) Position and Use of an External Power Supply for the DIs

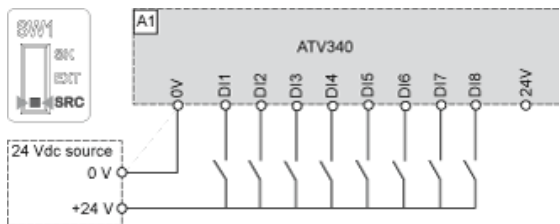

### Switch Set to SK (Sink) Position Using the Output Power Supply for the Digital Inputs

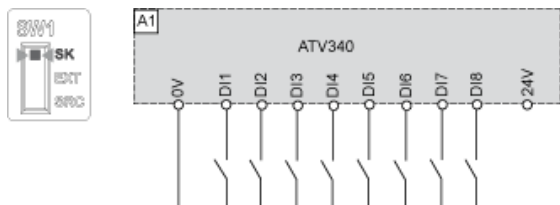

### Switch Set to EXT Position Using an External Power Supply for the DIs

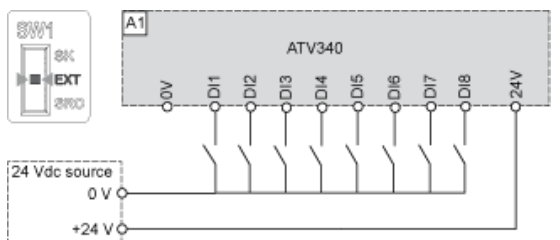

## Digital Outputs Wiring

### Digital Outputs: Internal Supply

Positive Logic, Source, European Style, DQ switches to +24V



(1) Relay or valve

Negative Logic, Sink, Asian Style, DQ switches to 0V

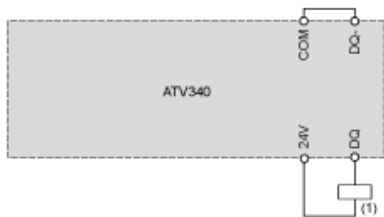

(1) Relay or valve

### Digital Outputs: External Supply

Positive Logic, Source, European Style, DQ switches to +24V

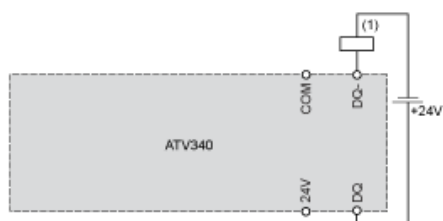

(1) Relay or valve

Negative Logic, Sink, Asian Style, DQ switches to 0V

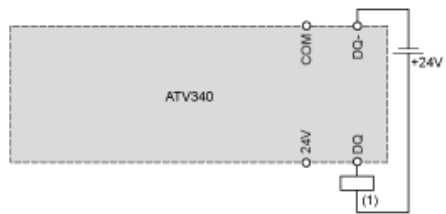

(1) Relay or valve

Open Loop Applications

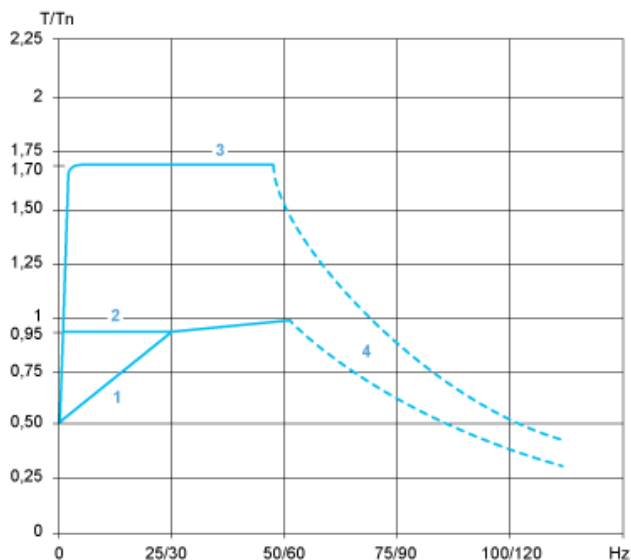

- 1 : Self-cooled motor: continuous useful torque
- 2 : Force-cooled motor: continuous useful torque
- 3 : Overtorque for 60 s maximum
- 4 : Torque in overspeed at constant power

Closed Loop Applications

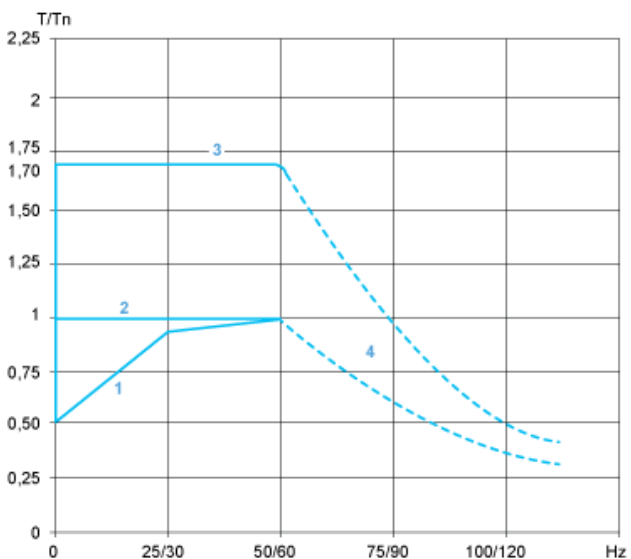

- 1 : Self-cooled motor: continuous useful torque
- 2 : Force-cooled motor: continuous useful torque
- 3 : Overtorque for 60 s maximum
- 4 : Torque in overspeed at constant power