



Galvenā

Produkta sērija	Altivar Machine ATV340
Produkta vai sastāvdaļas veids	Variable speed drive
Produkta specifiskais pielietojums	Machine
Variants	Standard version
Montāžas veids	Cabinet mount
Komunikācijas porta protokols	Ethernet/IP Modbus serial Modbus TCP
Tīkla fāžu skaits	3 fāzes
Supply frequency	50...60 Hz +/- 5 %
[Us] rated supply voltage	380...480 V - 15...10 %
Nominal output current	16,5 A
Motor power kW	11 KW normal duty 7,5 kW heavy duty
Motor power hp	15 Hp normal duty 10 hp heavy duty
EMC filter	Class C3 EMC filter integrated
IP degree of protection	IP20

Papildinošs

Discrete input number	5
Discrete input type	PTI programmable as pulse input 0...30 kHz, 24 V DC 30 V) DI1...DI5 safe torque off, 24 V DC 30 V)3.5 kOhm programmable
Number of preset speeds	16 preset speeds
Discrete output number	2,0
Discrete output type	Programmable output DQ1, DQ2 30 V DC 100 mA
Analogue input number	2
Analogue input type	AI1 software-configurable current 0...20 mA 250 Ohm 12 bits AI1 software-configurable temperature probe or water level sensor AI1 software-configurable voltage 0...10 V DC 31.5 kOhm 12 bits AI2 software-configurable voltage - 10...10 V DC 31.5 kOhm 12 bits
Analogue output number	2
Analogue output type	Software-configurable voltage AQ1 0...10 V DC 470 Ohm 10 bits Software-configurable current AQ1 0...20 mA 500 Ohm 10 bits
Relay output number	2
Izvada spriegums	<= power supply voltage
Relay output type	Relay outputs R1A Relay outputs R1C 100000 cikli Relay outputs R2A Relay outputs R2C 100000 cikli
Maximum switching current	Relay output R1C pretestības, cos phi = 1 3 A 250 V AC Relay output R1C pretestības, cos phi = 1 3 A 30 V DC Relay output R1C induktīvs, cos phi = 0,4 7 ms 2 A 250 V AC Relay output R1C induktīvs, cos phi = 0,4 7 ms 2 A 30 V DC Relay output R2C pretestības, cos phi = 1 5 A 250 V AC Relay output R2C pretestības, cos phi = 1 5 A 30 V DC Relay output R2C induktīvs, cos phi = 0,4 7 ms 2 A 250 V AC Relay output R2C induktīvs, cos phi = 0,4 7 ms 2 A 30 V DC

The information provided in this documentation contains general descriptions and/or technical characteristics of the performance of the products contained herein. This documentation is not intended as a substitute for and is not to be used for determining suitability or reliability of these products for specific user applications. It is the duty of any such user or integrator to perform the appropriate and complete risk analysis, evaluation and testing of the products with respect to the relevant specific application or use thereof. Neither Schneider Electric Industries SAS nor any of its affiliates or subsidiaries shall be responsible or liable for misuse of the information contained herein.

Minimum switching current	Relay output R1B 5 mA 24 V DC Relay output R2C 5 mA 24 V DC
Fiziskais "interfeiss"	2-wire RS 485
Konektora tips	3 RJ45
Method of access	Slave Modbus RTU Slave Modbus TCP
Pārtraides ātrums	4.8 kbit/s 9.6 kbit/s 19.2 kbit/s 38.4 kbit/s
Transmission frame	RTU
Adrešu skaits	1...247
Data format	8 bits, configurable odd, even or no parity
Type of polarization	No impedance
4 quadrant operation possible	"True"
Asynchronous motor control profile	Variable torque standard Constant torque standard Optimized torque mode
Synchronous motor control profile	Reluctance motor Permanent magnet motor
Pollution degree	2 IEC 61800-5-1
Maximum output frequency	0,599 kHz
Acceleration and deceleration ramps	S, U or customized Linear adjustable separately from 0.01...9999 s
Motor slip compensation	Automatic whatever the load Not available in permanent magnet motor law Can be suppressed Adjustable
Switching frequency	2...16 kHz adjustable 4...16 kHz with derating factor
Nominal switching frequency	4 kHz
Braking to standstill	By DC injection
Brake chopper integrated	"True"
Line current	22,0 A 380 V normal duty) 17,7 A 480 V normal duty) 25,6 A 380 V heavy duty) 20,4 A 480 V heavy duty)
Line current	25,6 A 380 V without line choke heavy duty) 20,4 A 480 V without line choke heavy duty) 22 A 380 V with external line choke normal duty) 17,7 A 480 V with external line choke normal duty) 14,6 A 380 V with external line choke heavy duty) 12,1 A 480 V with external line choke heavy duty)
Maksimālā ieejas strāva	25,6 A
Maximum output voltage	480 V
Apparent power	17 KVA 480 V normal duty) 17 kVA 480 V heavy duty)
Maximum transient current	26,4 A 60 s normal duty) 24,8 A 60 s heavy duty) 32,4 A 2 s normal duty) 29,7 A 2 s heavy duty)
Electrical connection	Skrūvju spaile 4...6 mm ² DC bus Skrūvju spaile 0.2...2.5 mm ² control Skrūvju spaile 1.5...6 mm ² motor Skrūvju spaile 2.5...6 mm ² line side
Prospective line I _{sc}	22 kA
Base load current at high overload	16,5 A
Base load current at low overload	24,0 A
Power dissipation in W	Natural convection 180 W 380 V 4 kHz heavy duty) Forced convection 180 W 380 V 4 kHz heavy duty) Natural convection 249 W 380 V 4 kHz normal duty) Forced convection 249 W 380 V 4 kHz normal duty)
Electrical connection	DC bus skrūvju spaile 4...6 mm ² AWG 12...AWG 10 Control skrūvju spaile 0.2...2.5 mm ² AWG 24...AWG 12 Motor skrūvju spaile 1.5...6 mm ² AWG 14...AWG 10 Line side skrūvju spaile 2.5...6 mm ² AWG 12...AWG 10

With safety function Safely Limited Speed (SLS)	"True"
With safety function Safe brake management (SBC/SBT)	"True"
With safety function Safe Operating Stop (SOS)	False
With safety function Safe Position (SP)	False
With safety function Safe programmable logic	False
With safety function Safe Speed Monitor (SSM)	False
With safety function Safe Stop 1 (SS1)	"True"
With sft fct Safe Stop 2 (SS2)	False
With safety function Safe torque off (STO)	"True"
With safety function Safely Limited Position (SLP)	False
With safety function Safe Direction (SDI)	False
Protection type	Termiskā aizsardzība motor Safe torque off motor Motor phase loss motor Termiskā aizsardzība drive Safe torque off drive Pārkaršana drive Overcurrent drive Output overcurrent between motor phase and earth drive Output overcurrent between motor phases drive Short-circuit between motor phase and earth drive Short-circuit between motor phases drive Motor phase loss drive DC Bus overvoltage drive Line supply overvoltage drive Line supply undervoltage drive Input supply loss drive Exceeding limit speed drive Break on the control circuit drive
Platums	110,0 mm
Augstums	270,0 mm
Dziļums	234,0 mm
Neto svars	3,0 kg
Continuous output current	24 A 4 kHz normal duty 16,5 A 4 kHz heavy duty

Vide

Operating altitude	<= 3000 m with current derating above 1000m
Operating position	Vertical +/- 10 degree
Produkta sertifikācija	UL[RETURN]CSA[RETURN]TÜV[RETURN]EAC[RETURN]CTick
Marķējums	CE
Standarti	IEC 61800-3 IEC 61800-5-1 IEC 60721-3 IEC 61508 IEC 13849-1 UL 618000-5-1 UL 508C
Assembly style	With heat sink
Electromagnetic compatibility	Electrostatic discharge immunity test level 3 IEC 61000-4-2 Radiated radio-frequency electromagnetic field immunity test level 3 IEC 61000-4-3 Electrical fast transient/burst immunity test level 4 IEC 61000-4-4 1.2/50 µs - 8/20 µs surge immunity test level 3 IEC 61000-4-5 Conducted radio-frequency immunity test level 3 IEC 61000-4-6
Environmental class (during operation)	Class 3C3 according to IEC 60721-3-3 Class 3S3 according to IEC 60721-3-3
Maximum acceleration under shock impact (during operation)	70 m/s ² at 22 ms
Maximum acceleration under vibrational stress (during operation)	5 m/s ² at 9...200 Hz
Maximum deflection under vibratory load (during operation)	1.5 mm at 2...9 Hz
Permitted relative humidity (during operation)	Class 3K5 according to EN 60721-3
Volume of cooling air	76,0 m ³ /h

Type of cooling	Forced convection
Pārsprieguma kategorija	Class III
Regulation loop	Adjustable PID regulator
Noise level	46,5 dB
Piesārņojuma pakāpe	2
Ambient air transport temperature	-40...70 °C
Ambient air temperature for operation	-15...50 °C without derating vertical position) 50...60 °C with derating factor vertical position)
Apkārteja gaisa temperatūra uzglabāšanai	-40...70 °C
Izolācija	Between power and control terminals

Iepakojšanas vienības

Pirmā iepakojuma vienības tips	PCE
Vienību skaits 1. iepakojumā	1
1. iepakojuma augstums	11,000 cm
1. iepakojuma platums	37,000 cm
1. iepakojuma garums	32,000 cm
1. iepakojuma svars	3,800 kg
Otrā iepakojuma vienības tips	P06
Vienību skaits 2. iepakojumā	10
2. iepakojuma augstums	75,000 cm
2. iepakojuma platums	60,000 cm
2. iepakojuma garums	80,000 cm
2. iepakojuma svars	51,000 kg

Piedāvājiēt ilgtspēju

Ilgtspējīgs piedāvājuma statuss	Green Premium izstrādājums
REACH regula	REACH Deklarācija
ES RoHS direktīva	Proaktīva atbilstība (uz izstrādājumu neattiecas ES RoHS juridiskās saistības)
Nesatur dzīvsudrabu	Jā
Ķīnas RoHS regula	Ķīnas RoHS Deklarācija
Informācija par RoHS izņēmumiem	Jā
Vides informācijas publiskošana	Produkta Ietekme Uz Vidi
Cirkularitātes profils	Informācija Par Eksploatācijas Izbeigšanu
WEEE	Eiropas Savienības tirgū no šī produkta ir jāatbrīvojas, ievērojot noteiktu atkritumu savākšanas kārtību, un produkts nedrīkst nonākt sadzīves atkritumu tvertnēs.
Atjaunināšanas iespējas	Pieejamas atjauninātas komponentes

Dimensions

Views: Front - Left - Rear

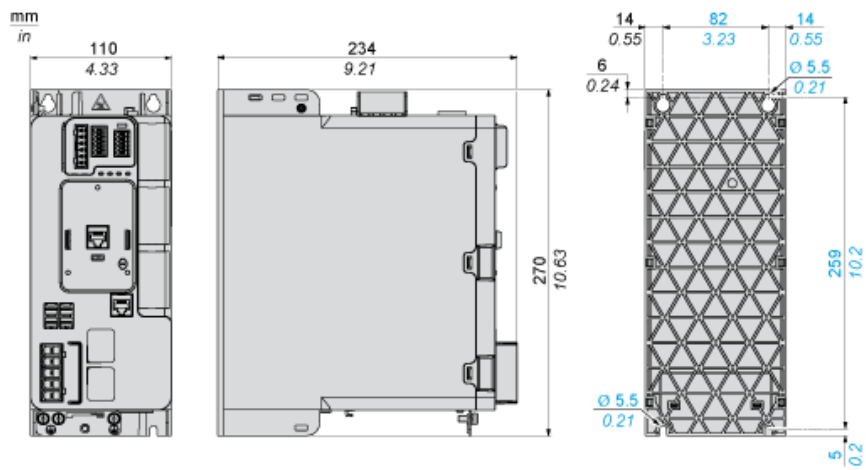

Clearance



Dimensions in mm

X1	X2	X3
≥ 100	≥ 100	≥ 60

Dimensions in in.

X1	X2	X3
≥ 3.94	≥ 3.94	≥ 2.36

Mounting Types

Mounting Type A: Side by Side IP20



Possible, at ambient temperature ≤ 50 °C (122 °F)

Mounting Type B: Individual IP20

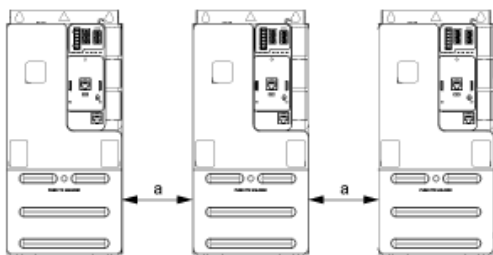

$a \geq 50$ mm (1.97 in.) from 50...60°C, no restriction below 50°C

Connections and Schema

Three-phase Power Supply with Upstream Breaking via Line Contactor Without Safety Function STO

Connection diagrams conforming to standards ISO13849 category 1 and IEC/EN 61508 capacity SIL1, stopping category 0 in accordance with standard IEC/EN 60204-1.



(1) Use relay output R1 set to operating state Fault to switch Off the product once an error is detected.

A1 : Drive

KM1 Line Contactor

Q2, Q3 : Circuit breakers

S1 : Pushbutton

S2 : Emergency stop

T1 : Transformer for control part

Three-phase Power Supply With Downstream Breaking via Switch Disconnecter



(1) Use relay output R1 set to operating state Fault to switch Off the product once an error is detected.

A1 : Drive

Q1 : Switch disconnecter

Sensor Connection



It is possible to connect either 1 or 3 sensors on terminals AI1.

Control Block Wiring Diagram

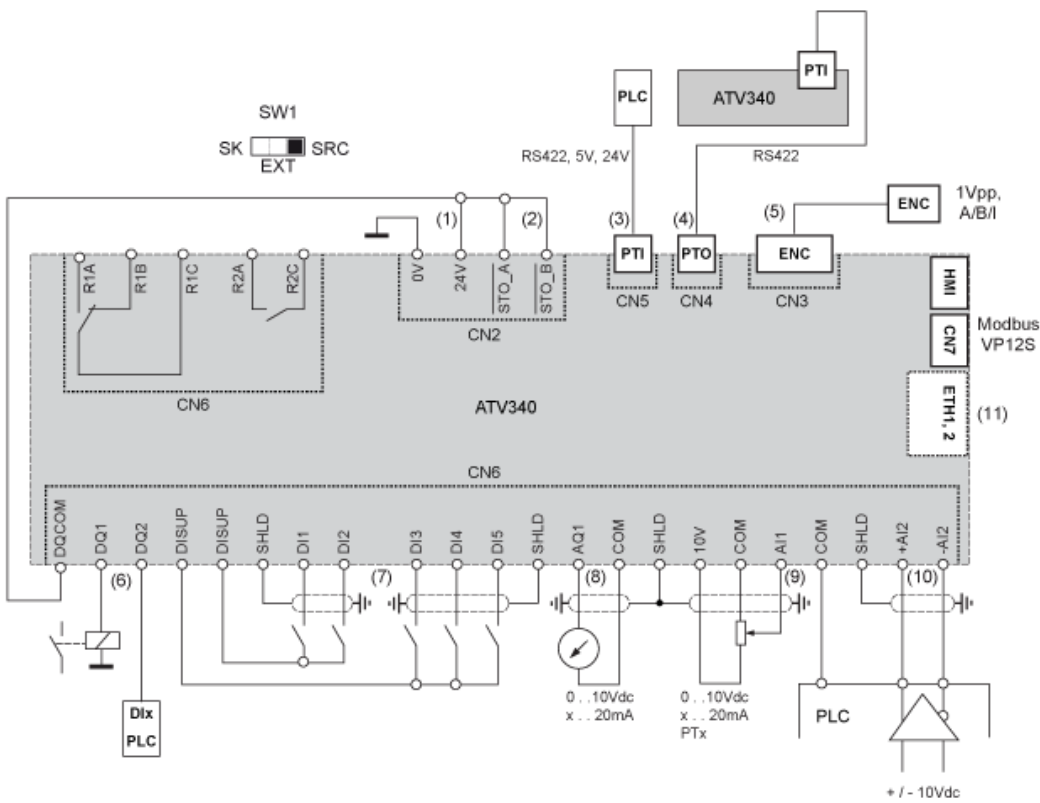

- (1) 24V supply (STO)
- (2) STO - Safe Torque Off
- (3) PTI - Pulse Train In
- (4) PTO - Pulse Train Out
- (5) Motor Encoder connection
- (6) Digital outputs
- (7) Digital inputs
- (8) Analog output
- (9) Analog input
- (10) Differential Analog Input
- (11) Ethernet port (only on Ethernet drive version)
- SW1 Sink/Source switch
- R1A, Fault relay
- R1B,
- R1C :
- R2A, Sequence relay
- R2C :

Digital Inputs Wiring

Digital Inputs: Internal Supply

Using DISUP Signal

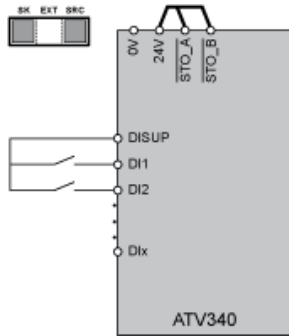

In SRC position DISUP outputs 24 V. In SK position DISUP is connected to 0 V.

Digital Inputs: External Supply

Positive Logic, Source, European Style

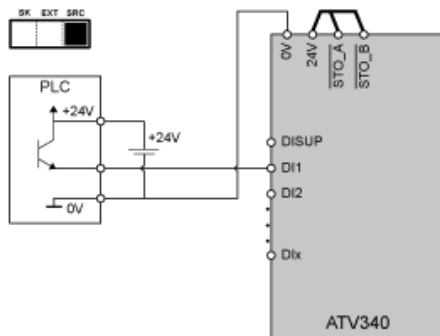

Negative Logic, Sink, Asian Style

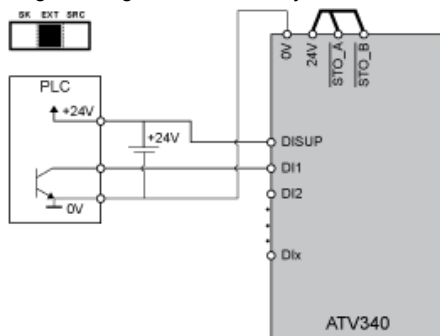

Digital Inputs: Internal supply

Negative Logic, Sink, Asian Style

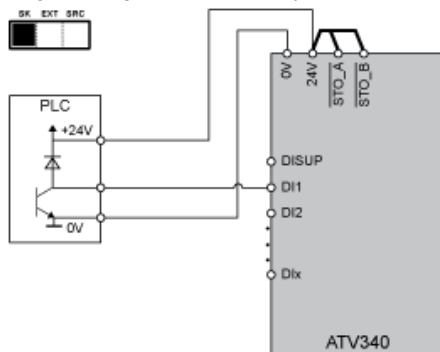

Digital Outputs Wiring

Digital Outputs: Internal Supply

Positive Logic, Source, European Style, DQCOM to +24V



(1) Relay or valve

Negative Logic, Sink, Asian Style, DQCOM to 0V



(1) Relay or valve

Digital Outputs: External Supply

Positive Logic, Source, European Style, DQCOM to +24V



(1) Relay or valve

Negative Logic, Sink, Asian Style, DQCOM to 0V



(1) Relay or valve

Open Loop Applications



- 1 : Self-cooled motor: continuous useful torque
- 2 : Force-cooled motor: continuous useful torque
- 3 : Overtorque for 60 s maximum
- 4 : Transient overtorque for 2 s maximum
- 5 : Torque in overspeed at constant power

Closed Loop Applications

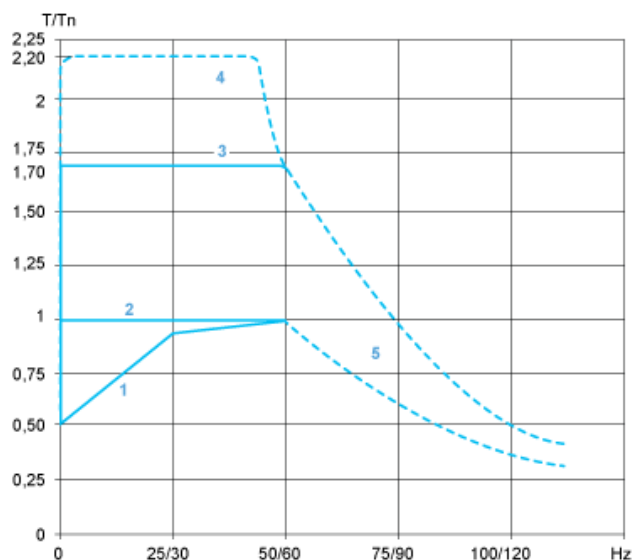

- 1 : Self-cooled motor: continuous useful torque
- 2 : Force-cooled motor: continuous useful torque
- 3 : Overtorque for 60 s maximum
- 4 : Transient overtorque for 2 s maximum
- 5 : Torque in overspeed at constant power