

ATV320U75N4C

Frekvenču pārveidotājs, Altivar Machine
ATV320, 7.5kW, 380 līdz 500V, 3 fāzes,
kompakts



Galvenā

Produkta sērija	Altivar Machine ATV320
Produkta vai sastāvdaļas veids	Variable speed drive
Produkta specifiskais pielietojums	Complex machines
Variants	Standard version
Format of the drive	Compact
Montāžas veids	Wall mount
Komunikācijas porta protokols	Modbus serial CANopen
Option card	Communication module, CANopen Communication module, EtherCAT Communication module, Profibus DP V1 Communication module, Profinet Communication module, Ethernet Powerlink Communication module, Ethernet/IP Communication module, DeviceNet
[Us] rated supply voltage	380...500 V - 15...10 %
Nominal output current	17,0 A
Motor power kW	7,5 kW heavy duty
EMC filter	Integrated
IP degree of protection	IP20

Papildinošs

Discrete input number	7
Discrete input type	STO safe torque off, 24 V DC 1.5 kOhm DI1...DI6 logic inputs, 24 V DC 30 V) DI5 programmable as pulse input 0...30 kHz, 24 V DC 30 V)
Discrete input logic	Positive logic (source) Negative logic (sink)
Discrete output number	3
Discrete output type	Open collector DQ+ 0...1 kHz 30 V DC 100 mA Open collector DQ- 0...1 kHz 30 V DC 100 mA
Analogue input number	3
Analogue input type	AI1 voltage 0...10 V DC 30 kOhm 10 bits AI2 bipolar differential voltage +/- 10 V DC 30 kOhm 10 bits AI3 current 0...20 mA (or 4-20 mA, x-20 mA, 20-x mA or other patterns by configuration) 250 Ohm 10 bits
Analogue output number	1
Analogue output type	Software-configurable current AQ1 0...20 mA 800 Ohm 10 bits Software-configurable voltage AQ1 0...10 V DC 470 Ohm 10 bits
Relay output type	Configurable relay logic R1A 1 NO 100000 cikli Configurable relay logic R1B 1 NC 100000 cikli Configurable relay logic R1C Configurable relay logic R2A 1 NO 100000 cikli Configurable relay logic R2C

The information provided in this documentation contains general descriptions and/or technical characteristics of the performance of the products contained herein. This documentation is not intended as a substitute for and is not to be used for determining suitability or reliability of these products for specific user applications. It is the duty of any such user or integrator to perform the appropriate and complete risk analysis, evaluation and testing of the products with respect to the relevant specific application or use thereof. Neither Schneider Electric Industries SAS nor any of its affiliates or subsidiaries shall be responsible or liable for misuse of the information contained herein.

Maximum switching current	Relay output R1A, R1B, R1C pretestības, cos phi = 1 3 A 250 V AC Relay output R1A, R1B, R1C pretestības, cos phi = 1 3 A 30 V DC Relay output R1A, R1B, R1C, R2A, R2C induktīvs, cos phi = 0,4 7 ms 2 A 250 V AC Relay output R1A, R1B, R1C, R2A, R2C induktīvs, cos phi = 0,4 7 ms 2 A 30 V DC Relay output R2A, R2C pretestības, cos phi = 1 5 A 250 V AC Relay output R2A, R2C pretestības, cos phi = 1 5 A 30 V DC
Minimum switching current	Relay output R1A, R1B, R1C, R2A, R2C 5 mA 24 V DC
Method of access	Slave CANopen
4 quadrant operation possible	"True"
Asynchronous motor control profile	Voltage/Frequency ratio, 5 points Flux vector control without sensor, standard Voltage/Frequency ratio - Energy Saving, quadratic U/f Flux vector control without sensor - Energy Saving Voltage/frequency ratio, 2 points
Synchronous motor control profile	Vector control without sensor
Transient overtorque	170...200 % of nominal motor torque
Maximum output frequency	0,599 kHz
Acceleration and deceleration ramps	Linear U S CUS Ramp switching Acceleration/Deceleration ramp adaptation Acceleration/deceleration automatic stop with DC injection
Motor slip compensation	Automatic whatever the load Adjustable 0...300 % Not available in voltage/frequency ratio (2 or 5 points)
Switching frequency	2...16 kHz adjustable 4...16 kHz with derating factor
Nominal switching frequency	4 kHz
Braking to standstill	By DC injection
Brake chopper integrated	"True"
Line current	26,5 A 380 V heavy duty) 18,7 A 500 V heavy duty)
Maksimālā ieejas strāva	26,5 A
Maximum output voltage	500 V
Apparent power	16,2 kVA 500 V heavy duty)
Tīkla frekvence	50...60 Hz
Relative symmetric network frequency tolerance	5 %
Prospective line I _{sc}	22 kA
Base load current at high overload	17,0 A
Power dissipation in W	Fan 229,0 W 380 V 4 kHz
With safety function Safely Limited Speed (SLS)	"True"
With safety function Safe brake management (SBC/SBT)	False
With safety function Safe Operating Stop (SOS)	False
With safety function Safe Position (SP)	False
With safety function Safe programmable logic	False
With safety function Safe Speed Monitor (SSM)	False
With safety function Safe Stop 1 (SS1)	"True"
With sft fct Safe Stop 2 (SS2)	False
With safety function Safe torque off (STO)	"True"
With safety function Safely Limited Position (SLP)	False
With safety function Safe Direction (SDI)	False
Protection type	Input phase breaks drive Overcurrent between output phases and earth drive Aizsardzība pret pārkaršanu drive Short-circuit between motor phases drive Termiskā aizsardzība drive
Platums	150 mm
Augstums	232,0 mm

Dziļums	178,0 mm
Neto svars	3,6 kg



Vide

Operating position	Vertical +/- 10 degree
Produkta sertifikācija	CE[RETURN]ATEX[RETURN]NOM[RETURN]GOST[RETURN]EAC[RETURN]RCM[RETURN]
Marķējums	CE ATEX UL CSA EAC RCM
Standarti	IEC 61800-5-1
Electromagnetic compatibility	Electrostatic discharge immunity test level 3 IEC 61000-4-2 Radiated radio-frequency electromagnetic field immunity test level 3 IEC 61000-4-3 Electrical fast transient/burst immunity test level 4 IEC 61000-4-4 1.2/50 µs - 8/20 µs surge immunity test level 3 IEC 61000-4-5 Conducted radio-frequency immunity test level 3 IEC 61000-4-6 Voltage dips and interruptions immunity test IEC 61000-4-11
Environmental class (during operation)	Class 3C3 according to IEC 60721-3-3 Class 3S2 according to IEC 60721-3-3
Maximum acceleration under shock impact (during operation)	150 m/s ² at 11 ms
Maximum acceleration under vibrational stress (during operation)	10 m/s ² at 13...200 Hz
Maximum deflection under vibratory load (during operation)	1.5 mm at 2...13 Hz
Permitted relative humidity (during operation)	Class 3K5 according to EN 60721-3
Volume of cooling air	60 m ³ /h
Pārsprieguma kategorija	III
Regulation loop	Adjustable PID regulator
Speed accuracy	+/- 10 % of nominal slip 0.2 Tn to Tn
Piesārņojuma pakāpe	2
Ambient air transport temperature	-25...70 °C
Ambient air temperature for operation	-10...50 °C without derating 50...60 °C with derating factor
Apkārtējā gaisa temperatūra uzglabāšanai	-25...70 °C

Iepakojšanas vienības

Pirmā iepakojuma vienības tips	PCE
Vienību skaits 1. iepakojumā	1
1. iepakojuma augstums	19,500 cm
1. iepakojuma platums	22,000 cm
1. iepakojuma garums	33,000 cm
1. iepakojuma svars	4,737 kg
Otrā iepakojuma vienības tips	P06
Vienību skaits 2. iepakojumā	10
2. iepakojuma augstums	75,000 cm
2. iepakojuma platums	60,000 cm
2. iepakojuma garums	80,000 cm
2. iepakojuma svars	58,000 kg

Piedāvājiēt ilgtspēju

Ilgspējīgs piedāvājuma statuss	Green Premium izstrādājums
REACH regula	 REACH Deklarācija
ES RoHS direktīva	Proaktīva atbilstība (uz izstrādājumu neattiecas ES RoHS juridiskās saistības)
Nesatur dzīvsudrabu	Jā
Ķīnas RoHS regula	 Ķīnas RoHS Deklarācija

Informācija par RoHS izņēmumiem	Jā
Vides informācijas publicēšana	Produkta Ietekme Uz Vidi
Cirkularitātes profils	Informācija Par Eksploatācijas Izbeigšanu
WEEE	Eiropas Savienības tirgū no šī produkta ir jāatbrīvojas, ievērojot noteiktu atkritumu savākšanas kārtību, un produkts nedrīkst nonākt sadzīves atkritumu tvertnēs.
Atjaunināšanas iespējas	Pieejamas atjauninātas komponentes

Right and Front Views without EMC Plate

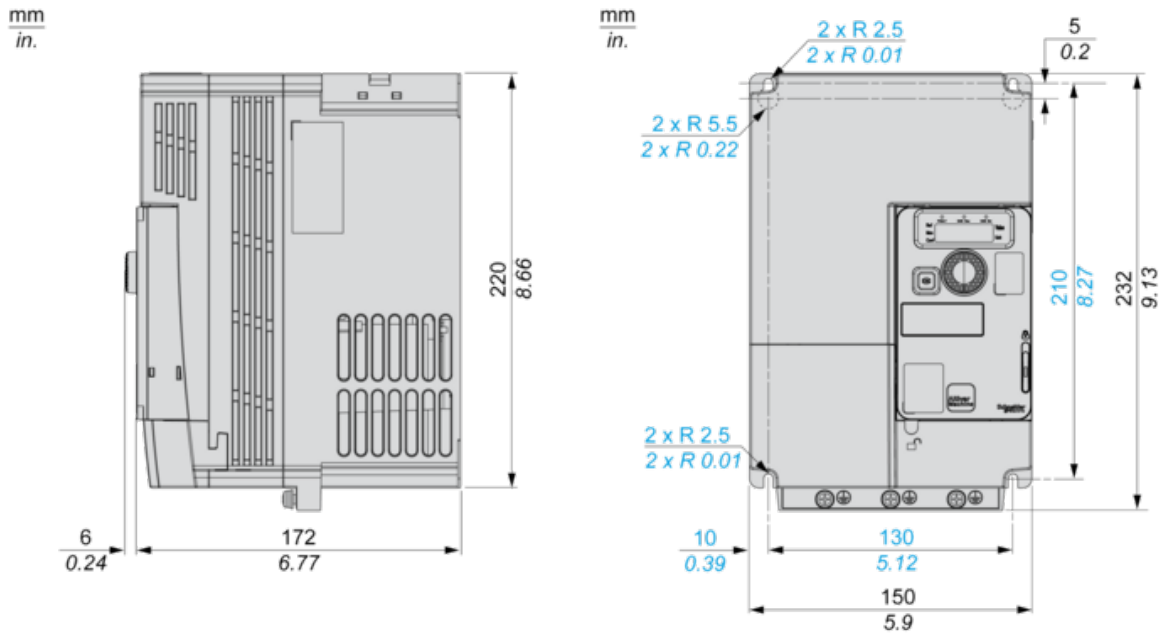

Right and Front Views with EMC Plate

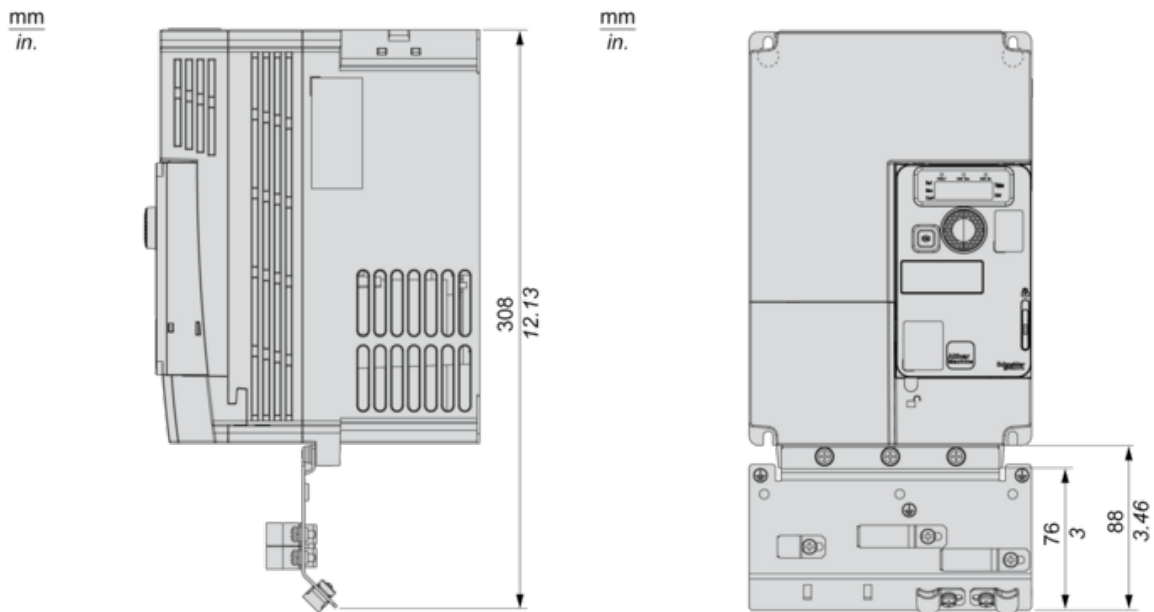

Mounting Types

Mounting Type A: Individual with Ventilation Cover

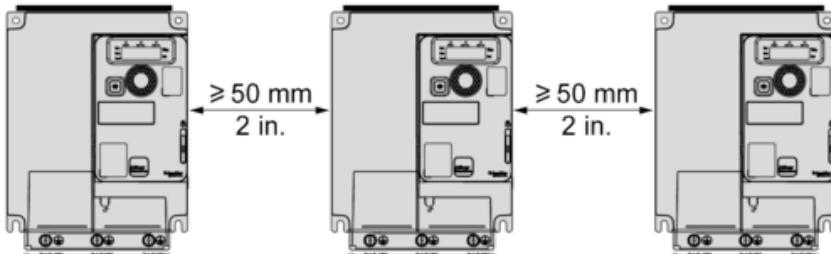

Only Possible at Ambient Temperature Less or Equal to 50 °C (122 °F)

Mounting Type B: Side by Side, Ventilation Cover Removed

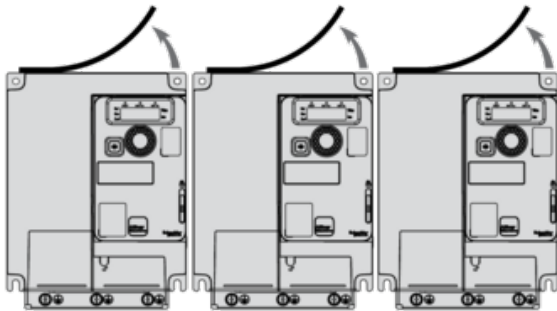

Mounting Type C: Individual, Ventilation Cover Removed

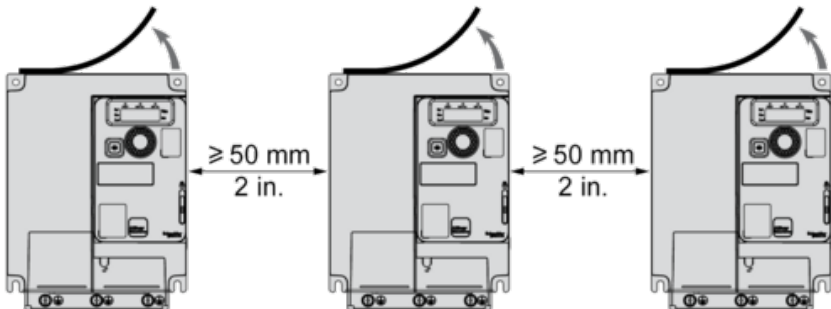

For Operation at Ambient Temperature Above 50 °C (122 °F)

Connection Diagrams

Diagram with Line Contactor

Connection diagrams conforming to standards ISO13849 category 1 and IEC/EN 61508 capacity SIL1, stopping category 0 in accordance with standard IEC/EN 60204-1.



- (1) Line choke (if used)
- (2) Fault relay contacts, for remote signaling of drive status

Diagram with Switch Disconnect

Connection diagrams conforming to standards EN 954-1 category 1 and IEC/EN 61508 capacity SIL1, stopping category 0 in accordance with standard IEC/EN 60204-1.

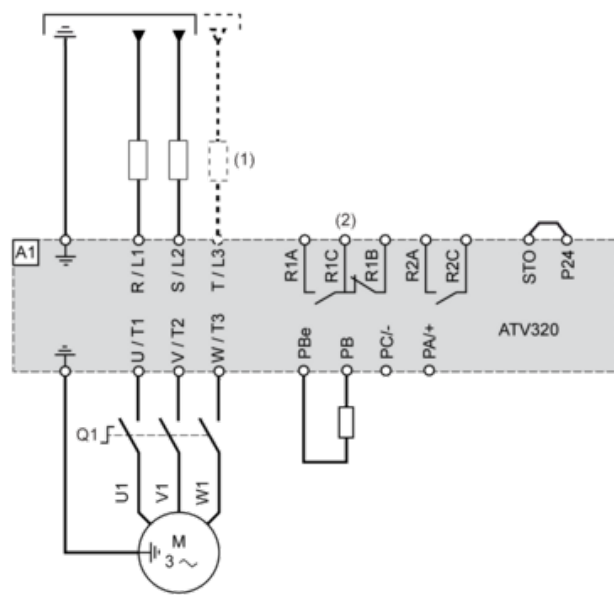

- (1) Line choke (if used)
- (2) Fault relay contacts, for remote signaling of drive status

Control Connection Diagram in Source Mode



- (1) Analog output
- (2) Analog inputs
- (3) Reference potentiometer (10 kOhm maxi)
- (4) Digital inputs

Digital Inputs Wiring

The logic input switch (SW1) is used to adapt the operation of the logic inputs to the technology of the programmable controller outputs. Switch SW1 set to "Source" position and use of the output power supply for the DIs.



Switch SW1 set to "Source" position and use of an external power supply for the DIs.



Switch SW1 set to "Sink Int" position and use of the output power supply for the DIs.



Switch SW1 set to "Sink Ext" position and use of an external power supply for the DIs.

ATV320●●●●●B

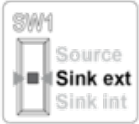

ATV320●●●●●C
ATV320●●●●●W(S)

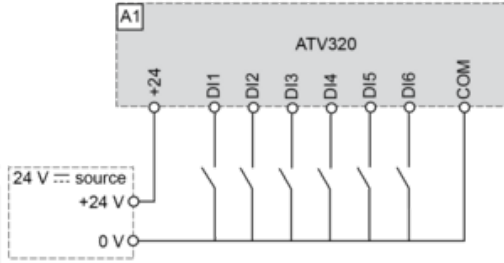
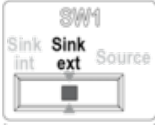

Derating Curves

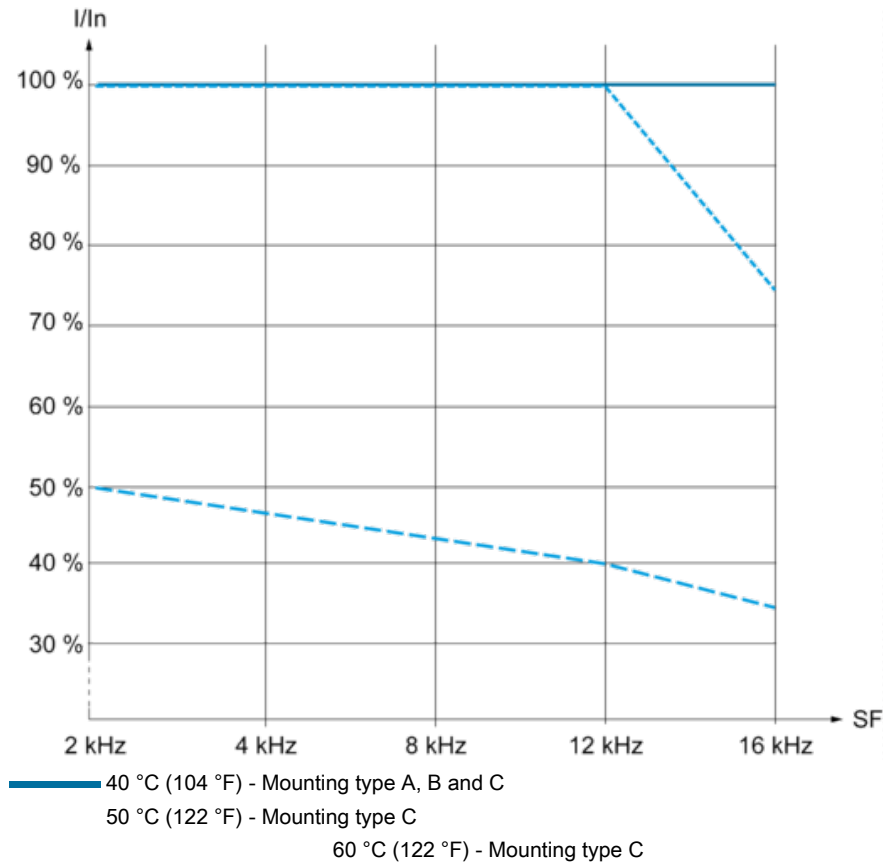

In : Nominal Drive Current
SF : Switching Frequency