

ATS22D62Q

soft starter-ATS22-control 220V-power
230V(15kW)/400...440V(30kW)



Galvenā

Produkta sērija	Altistart 22
Produkta vai sastāvdaļas veids	Soft starter
Produkta mērķa pielietojums	Asynchronous motors
Produkta specifiskais pielietojums	Pumps and fans
Component name	ATS22
Tīkla fāžu skaits	3 fāzes
[Us] rated supply voltage	230...440 V - 15...10 %
Motor power kW	15 KW 230 V 30 KW 400 V 30 kW 440 V
Factory setting current	57 A
Power dissipation in W	59 W for standard applications
Utilisation category	AC-53A
Type of start	Start with torque control (current limited to 3.5 In)
IcL starter rating	62 A connection in the motor supply line for standard applications
IP degree of protection	IP20

Papildinošs

Assembly style	With heat sink
Pieejamā funkcija	Internal bypass
Supply voltage limits	195...484 V
Supply frequency	50...60 Hz - 10...10 %
Tīkla frekvence	45...66 Hz
Device connection	To the motor delta terminals In the motor supply line
[Uc] control circuit voltage	230 V - 15...10 % 50/60 Hz
Control circuit consumption	20 W
Discrete output number	2
Discrete output type	Relay outputs R1 230 V running, alarm, trip, stopped, not stopped, starting, ready C/O Relay outputs R2 230 V running, alarm, trip, stopped, not stopped, starting, ready C/O
Minimum switching current	100 mA 12 V DC relay outputs)
Maximum switching current	5 A 250 V AC pretestības 1 relay outputs 5 A 30 V DC pretestības 1 relay outputs 2 A 250 V AC induktīvs 0,4 20 ms relay outputs 2 A 30 V DC induktīvs 7 ms relay outputs
Discrete input number	3
Discrete input type	LI1, LI2, LI3) logic, 5 mA 4.3 kOhm
Discrete input voltage	24 V <= 30 V
Discrete input logic	Positive logic LI1, LI2, LI3 < 5 V <= 2 mA > 11 V, >= 5 mA
Izejas strāva	0.4...1 Icl regulējami
PTC probe input	750 Ohm
Komunikācijas porta protokols	Modbus
Konektora tips	1 RJ45
Communication data link	Serial

The information provided in this documentation contains general descriptions and/or technical characteristics of the performance of the products contained herein. This documentation is not intended as a substitute for and is not to be used for determining suitability or reliability of these products for specific user applications. It is the duty of any such user or integrator to perform the appropriate and complete risk analysis, evaluation and testing of the products with respect to the relevant specific application or use thereof. Neither Schneider Electric Industries SAS nor any of its affiliates or subsidiaries shall be responsible or liable for misuse of the information contained herein.

Fiziskais "interfeiss"	RS485 multidrop
Pārraides ātrums	4800, 9600 or 19200 bps
Papildaprīkojuma uzstādīšana	31
Protection type	Phase failure line Termiskā aizsardzība motor Termiskā aizsardzība starter
Marķējums	CE
Type of cooling	Forced convection
Operating position	Vertical +/- 10 degree
Augstums	295 mm
Platums	145 mm
Dziļums	207 mm
Neto svars	12 kg
Motor power range AC-3	15...25 kW 200...240 V 3 fāzes 30...50 kW 380...440 V 3 fāzes
Motor starter type	Soft starter

Vide

Electromagnetic compatibility	Conducted and radiated emissions level A IEC 60947-4-2 Damped oscillating waves level 3 IEC 61000-4-12 Electrostatic discharge level 3 IEC 61000-4-2 Immunity to electrical transients level 4 IEC 61000-4-4 Immunity to radiated radio-electrical interference level 3 IEC 61000-4-3 Voltage/current impulse level 3 IEC 61000-4-5
Standarti	IEC 60947-4-2
Produkta sertifikācija	C-Tick[RETURN]CCC[RETURN]UL[RETURN]CSA[RETURN]GOST
Vibration resistance	1 gn 13...200 Hz)IEC 60068-2-6 1.5 mm 2...13 Hz)IEC 60068-2-6
Shock resistance	15 gn 11 ms IEC 60068-2-27
Noise level	45 dB
Pollution degree	Level 2 IEC 60664-1
Relative humidity	0...95 % without condensation or dripping water IEC 60068-2-3
Ambient air temperature for operation	-10...40 °C without derating) 40...60 °C with current derating 2.2 % per °C)
Apkārtējā gaisa temperatūra uzglabāšanai	-25...70 °C
Operating altitude	<= 1000 m without derating > 1000...< 2000 m with current derating of 2.2 % per additional 100 m

Iepakojšanas vienības

Pirmā iepakojuma vienības tips	PCE
Vienību skaits 1. iepakojumā	1
1. iepakojuma augstums	31,0 cm
1. iepakojuma platums	23,5 cm
1. iepakojuma garums	36,0 cm
1. iepakojuma svars	8,262 kg
Otrā iepakojuma vienības tips	P06
Vienību skaits 2. iepakojumā	6
2. iepakojuma augstums	73,5 cm
2. iepakojuma platums	80,0 cm
2. iepakojuma garums	60,0 cm
2. iepakojuma svars	64,0 kg

Piedāvājiēt ilgtspēju

REACH regula	REACH Deklarācija
ES RoHS direktīva	Proaktīva atbilstība (uz izstrādājumu neattiecas ES RoHS juridiskās saistības)
Nesatur dzīvsudrabu	Jā
Ķīnas RoHS regula	Ķīnas RoHS Deklarācija
Informācija par RoHS izņēmumiem	Jā
WEEE	Eiropas Savienības tirgū no šī produkta ir jāatbrīvojas, ievērojot noteiktu atkritumu savākšanas kārtību, un produkts nedrīkst nonākt sadzīves atkritumu tvertnēs.

Līguma garantija

Garantija	18 months
-----------	-----------

Frame Size B

Dimensions

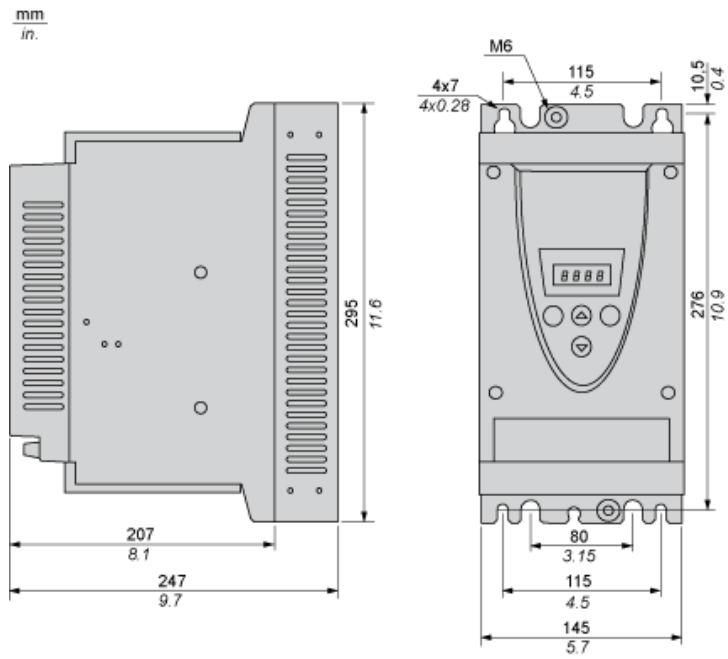

Precautions

Standards

The Altistart 22 soft starter is compliant with pollution Degree 2 as defined in NEMA ICS1-1 or IEC 60664-1.

For environment pollution degree 3, install the Altistart 22 soft starter inside a cabinet type 12 or IP54.

⚠ DANGER

HAZARD OF ELECTRIC SHOCK, EXPLOSION, OR ARC FLASH

ATS22 soft starters are open devices and must be mounted in a suitable enclosure.

Failure to follow these instructions will result in death or serious injury.

Air Circulation

Leave sufficient free space to help the air required for cooling purposes to circulate from the bottom to the top of the unit.

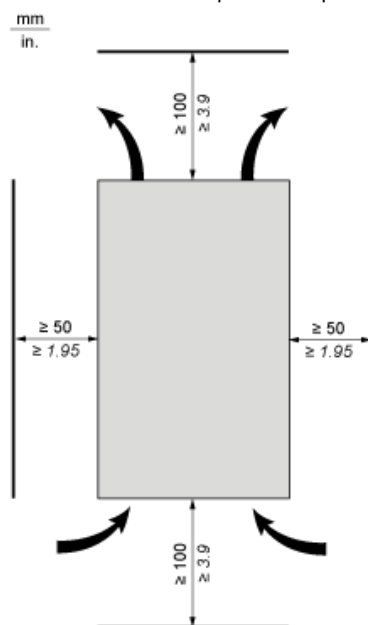

Overheating

To avoid the soft starter to overheat, respect the following recommendations:

- Mount the Altistart 22 Soft Starter within $\pm 10^\circ$ of vertical.
- Do not locate the Altistart 22 Soft Starter near heat radiating elements.
- Electrical current through the Altistart 22 Soft Starter will result in heat losses that must be dissipated into the ambient air immediately surrounding the soft starter. To help prevent a thermal fault, provide sufficient enclosure cooling and/or ventilation to limit the ambient temperature around the soft starter.
- If several soft starters are installed in a control panel, arrange them in a row. Do not stack soft starters. Heat generated from the bottom soft starter can adversely affect the ambient temperature around the top soft starter.

Mounting

Connection Between the Fan and the Altistart 22 Soft Starter

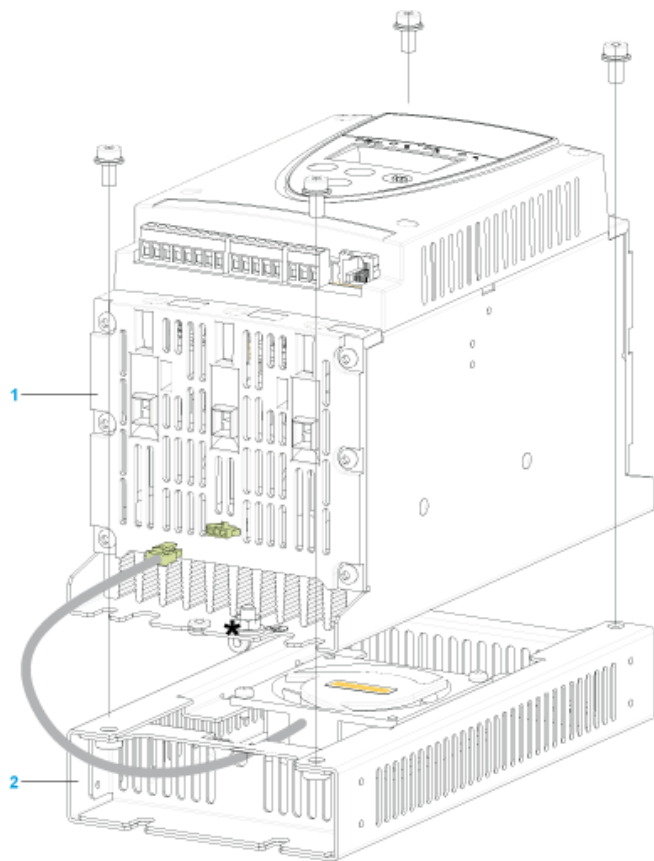

- 1 Altistart 22 Soft Starter
- 2 Fan

Wall mounted or Floor-standing Enclosure with IP 23 Degree of protection

Introduction

To help proper air circulation in the soft starter, grilles and forced ventilation can be installed.

Ventilation Grilles

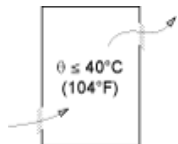

Forced Ventilation Unit

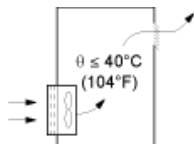

Power Terminal

Cage Style

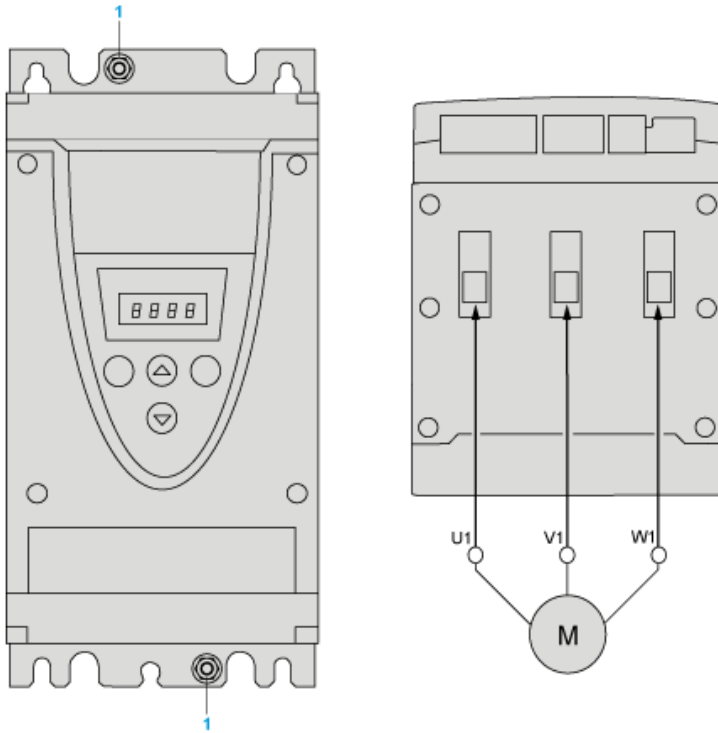

1 Ground connection

Power connections, minimum and maximum wiring capabilities, tightening torque

			IEC cable	UL cable
Power supply and output to motor	Size/gauge	min	4 mm (a)	10 AWG (a)
max	50 mm	1/0 AWG		
Tightening torque	min	8 N.m	70 lb.in	
max	8 N.m	70 lb.in		
Strip length		15 mm	0.6 in.	

Power connections, minimum required wiring section

IEC cable mm ² (Cu 70°C/158°F) (1)	UL cable AWG (Cu 75°C/167°F) (1)
16	4

230 Vac control, logic Inputs (LI) 24 Vdc, 3-wire control

With Line Contactor, Freewheel or Controlled Stop

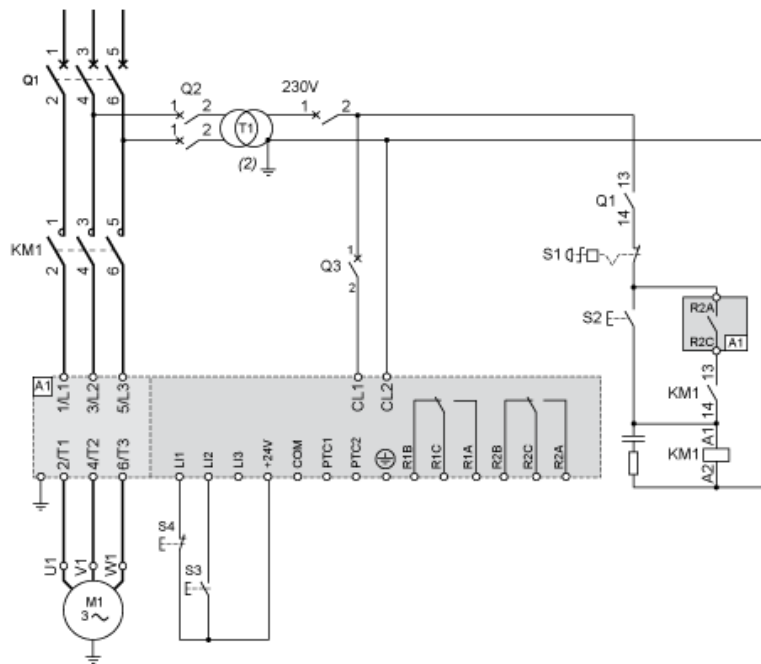

230 Vac control, logic Inputs (LI) 24 Vdc, 2-wire control, freewheel stop

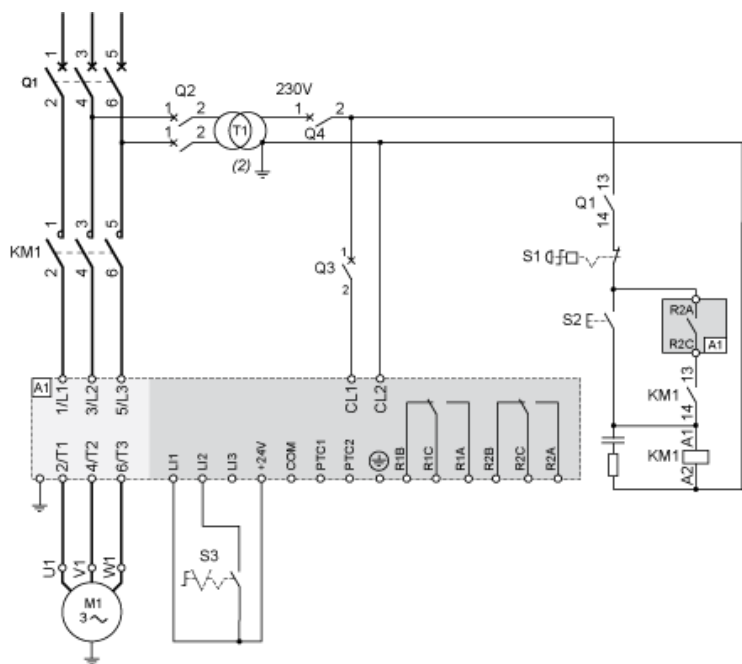

Connection in the motor delta winding in series with each winding

Wiring

ATS22 soft starters connected to motors with the delta connections can be inserted in series in the motor windings.

The following wiring requires particular attention. It is documented in the Altistart 22 Soft start - soft stop unit user manual. Please contact Schneider Electric commercial organisation for further informations.

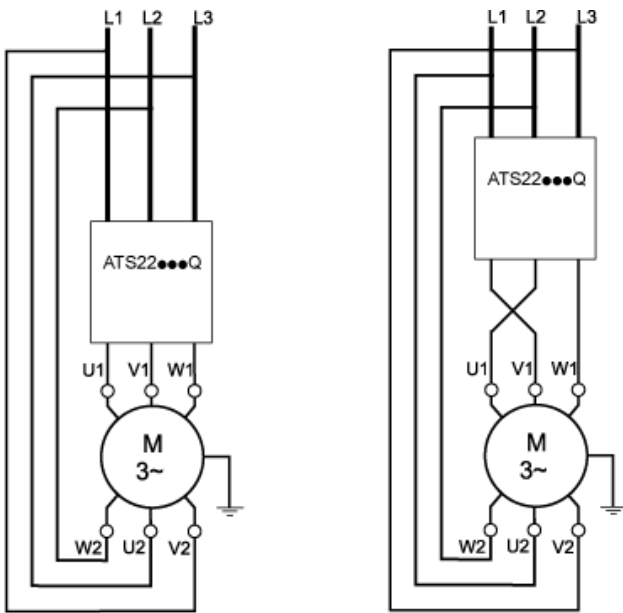

Example

A 400 V - 110 kW motor with a line current of 195 A (nominal current for the delta connection). The current in each winding is equal to $195/1.5$ or 130 A. The rating is determined by selecting the soft starter with a permanent nominal current (ICL) just above this current.

Motor Thermal Protection - Cold Curves

Curves

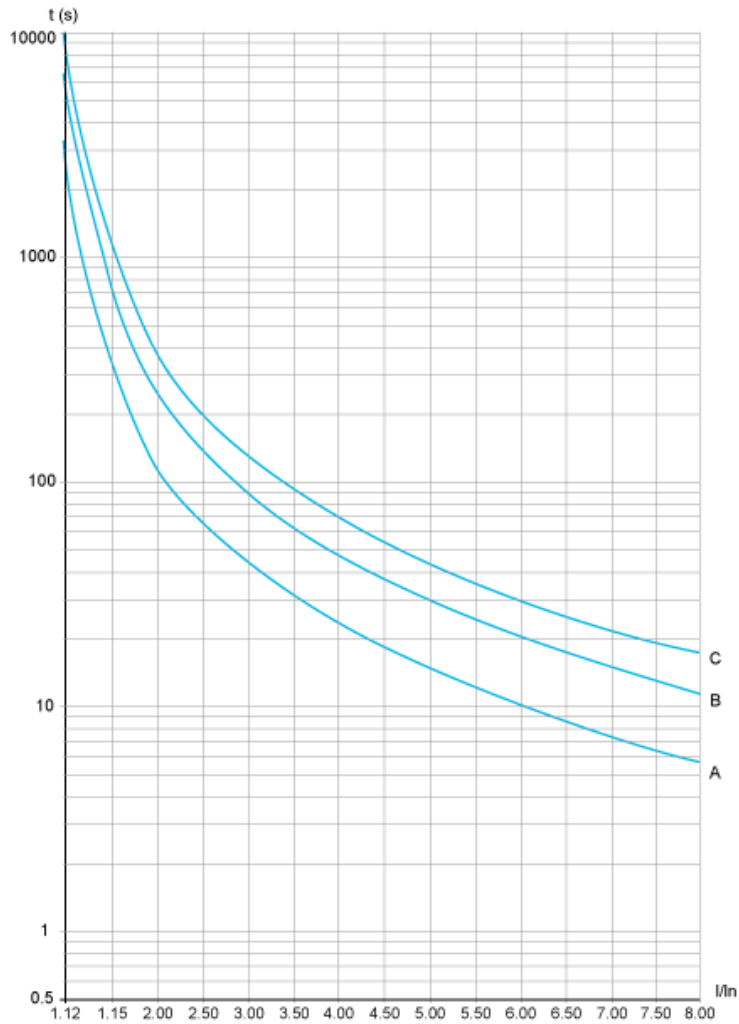

- A Class 10
- B Class 20
- C Class 30

Trip time for a Standard Application (Class 10)

3.5 In
32 s

Trip time for a Severe Application (Class 20)

3.5 In
63 s

Trip time for a Severe Application (Class 30)

3.5 In
95 s

Curves

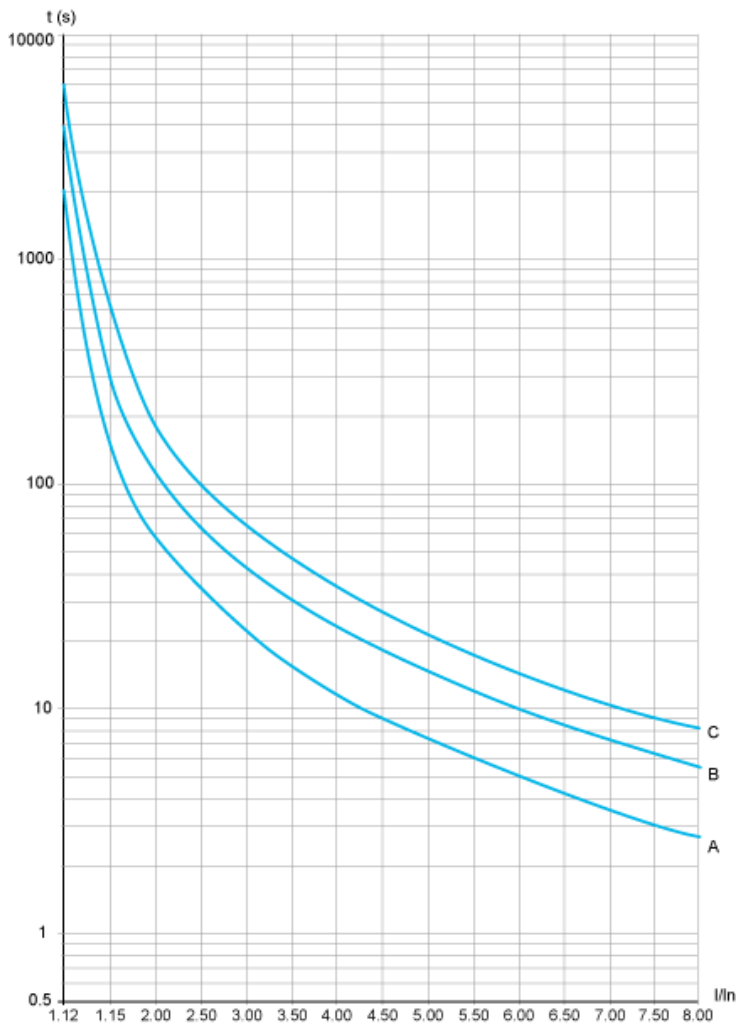

- A Class 10
- B Class 20
- C Class 30

Trip time for a Standard Application (Class 10)

3.5 In
16 s

Trip time for a Severe Application (Class 20)

3.5 In
32 s

Trip time for a Severe Application (Class 30)

3.5 In
48 s