



## Galvenā

Produkta sērija	Modicon TM3
Produkta vai sastāvdaļas veids	Analog input module
Saderība ar	Modicon M221 Modicon M241 Modicon M251 Modicon M262
Analogue input number	2
Analogue input type	Current 4...20 mA Current 0...20 mA Voltage 0...10 V Voltage - 10...10 V

## Papildinošs

Analogue input resolution	16 bits 15 bits + sign
Permissible continuous overload	13 V voltage 40 mA current
Input impedance	<= 50 Ohm current >= 1 MOhm voltage
LSB value	0.153 mV 0...10 V voltage 0.305 mV - 10...10 V voltage 0.305 µA 0...20 mA current 0.244 µA 4...20 mA current
Conversion time	1 ms + 1 ms per channel + 1 controller cycle time
Sampling duration	1 ms
Absolute accuracy error	+/- 0.1 % of full scale at 25 °C +/- 1 % of full scale
Temperature drift	+/- 0.006 %FS/°C
Repeat accuracy	+/-0.5 %FS
Non-linearity	+/- 0.01 %FS
Cross talk	<= 1 LSB
[Us] nominālais barošanas spriegums	24&nbsp;&V DC
Supply voltage limits	20,4...28,8 V
Type of cable	Twisted shielded pairs cable <30 m ievade
Current consumption	30 mA 5 V DC via bus connector no load 40 mA 5 V DC via bus connector pilna slodze 25 mA 24&nbsp;&V DC via external supply
Lokālā signalizēšana	Priekš PWR 1 LED (zaļš)
Electrical connection	11 x 2,5 mm <sup>2</sup> removable screw terminal block pitch 5.08 mm for inputs and supply
Insulation	Between input and supply 1500 V AC Between input and internal logic 500 V AC
Markējums	CE
Surge withstand	1 kV power supply common mode IEC 61000-4-5 0,5 kV power supply differential mode IEC 61000-4-5 1 kV input common mode IEC 61000-4-5
Mounting support	Top hat type TH35-15 rail IEC 60715 Top hat type TH35-7.5 rail IEC 60715 Plate or panel with fixing kit
Augstums	90 mm
Dziļums	70 mm

The information provided in this documentation contains general descriptions and/or technical characteristics of the performance of the products contained herein. This documentation is not intended as a substitute for and is not to be used for determining suitability or reliability of these products for specific user applications. It is the duty of any such user or integrator to perform the appropriate and complete risk analysis, evaluation and testing of the products with respect to the relevant specific application or use thereof. Neither Schneider Electric Industries SAS nor any of its affiliates or subsidiaries shall be responsible or liable for misuse of the information contained herein.

Platums	23,6 mm
Neto svars	0,115 kg

## Vide

Standarti	IEC 61131-2
Produkta sertifikācija	CE[RETURN]UKCA[RETURN]RCM[RETURN]EAC[RETURN]cULus[RETURN]cULus HazLoc
Resistance to electrostatic discharge	8 kV in air IEC 61000-4-2 4 kV on contact IEC 61000-4-2
Resistance to electromagnetic fields	10 V/m 80 MHz...1 GHz IEC 61000-4-3 3 V/m 1.4 GHz...2 GHz IEC 61000-4-3 1 V/m 2 GHz...3 GHz IEC 61000-4-3
Resistance to magnetic fields	30 A/m IEC 61000-4-8
Resistance to fast transients	1 kV IEC 61000-4-4 I/O)
Resistance to conducted disturbances	10 V 0.15...80 MHz IEC 61000-4-6 3 V spot frequency (2, 3, 4, 6.2, 8.2, 12.6, 16.5, 18.8, 22, 25 MHz) Marine specification (LR, ABS, DNV, GL)
Electromagnetic emission	Radiated emissions 40 dB $\mu$ V/m QP class A 10 m)30...230 MHz IEC 55011 Radiated emissions 47 dB $\mu$ V/m QP class A 10 m)230...1000 MHz IEC 55011
Immunity to microbreaks	10 ms
Ambient air temperature for operation	-10...55 °C horizontal installation -10...35 °C vertical installation
Apkārtējā gaisa temperatūra uzglabāšanai	-25...70 °C
Relative humidity	10...95 %, without condensation in operation) 10...95 %, without condensation in storage)
IP aizsardzības pakāpe	IP20
Piesārņojuma pakāpe	2
Darbības augstums	0...2000 m
Uzglabāšanas augstums	0...3000 m
Vibration resistance	3.5 mm 5...8,4 Hz DIN sliede 3 gn 8,4...150 Hz DIN sliede
Shock resistance	15 gn 11 ms

## Iepakojšanas vienības

Pirmā iepakojuma vienības tips	PCE
Vienību skaits 1. iepakojumā	1
1. iepakojuma augstums	7,46 cm
1. iepakojuma platums	10,645 cm
1. iepakojuma garums	12,707 cm
1. iepakojuma svars	220,0 g
Otrā iepakojuma vienības tips	S04
Vienību skaits 2. iepakojumā	42
2. iepakojuma augstums	30 cm
2. iepakojuma platums	40 cm
2. iepakojuma garums	60 cm
2. iepakojuma svars	10,341 kg
Trešā iepakojuma vienības tips	P12
Vienību skaits 3. iepakojumā	504
3. iepakojuma augstums	105 cm
3. iepakojuma platums	120 cm
3. iepakojuma garums	80 cm
3. iepakojuma svars	134 kg

## Piedāvājiēt ilgtspēju

Ilgspējīgs piedāvājuma statuss	Green Premium izstrādājums
REACH regula	<a href="#">REACH Deklarācija</a>
ES RoHS direktīva	Proaktīva atbilstība (uz izstrādājumu neattiecas ES RoHS juridiskās saistības) <a href="#">ES RoHS deklarācija</a>
Nesatur toksiskus smagos metālus	Jā
Nesatur dzīvsudrabu	Jā
Ķīnas RoHS regula	<a href="#">Ķīnas RoHS Deklarācija</a>
Informācija par RoHS izņēmumiem	<a href="#">Jā</a>
Vides informācijas publicēšana	<a href="#">Produkta Ietekme Uz Vidi</a>
Cirkularitātes profils	<a href="#">Informācija Par Eksploatācijas Izbeigšanu</a>
WEEE	Eiropas Savienības tirgū no šī produkta ir jāatbrīvojas, ievērojot noteiktu atkritumu savākšanas kārtību, un produkts nedrīkst nonākt sadzīves atkritumu tvertnēs.
Nesatur PVH	Jā

Dimensions

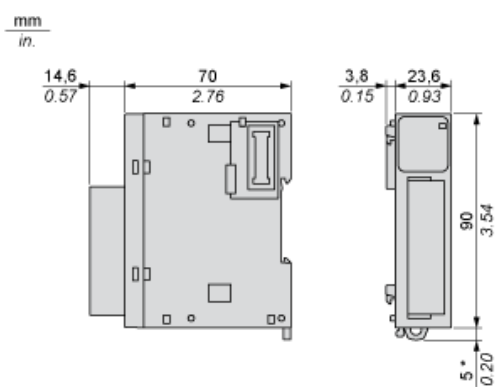

(\*) 8.5 mm/0.33 in when the clamp is pulled out.

Spacing Requirements



Mounting on a Rail



Incorrect Mounting

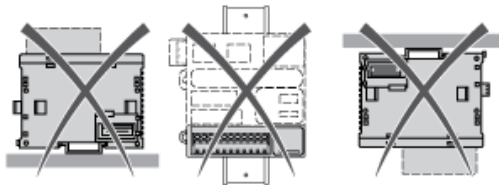

Mounting on a Panel Surface



- (1) Install a mounting strip

Mounting Hole Layout



## Analogue Input Module

### Wiring Diagram (Current / Voltage)

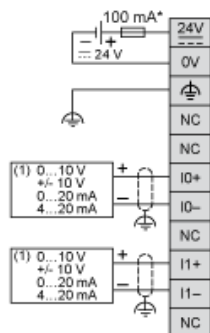

(\*) Type T fuse

(1) Current/Voltage analog output device