



F&F Filipowski L.P.  
Konstantynowska 79/81, 95-200 Pabianice, POLAND  
phone/fax (+48 42) 215 23 83 / (+48 42) 227 09 71  
www.fif.com.pl; e-mail: biuro@fif.com.pl

## DRM-02

Microwave motion sensor,  
with presence detector



**Do not dispose of this device in the trash along with other waste!**

According to the Law on Waste, electro coming from households free of charge and can give any amount to up to that end point of collection, as well as to store the occasion of the purchase of new equipment (in accordance with the principle of old-for-new, regardless of brand). Electro thrown in the trash or abandoned in nature, pose a threat to the environment and human health.



### Purpose

The motion sensor is used for automatic and temporary switching on of lighting if a person or other object appears in places such as hallways, courtyards, driveways, garages, etc.

The sensor can detect movement through wooden, plasterboard, glass and plastic panels.

### Functioning

The DRM microwave sensor operates as a radar by using high frequency electromagnetic waves to detect movement in a monitored area. It is most effective when the movement takes place directly towards the sensor. In addition, the DRM has a built-in twilight switch that prevents the controlled lighting from switching on during the day. When motion is detected after dusk, the lighting will be switched on and will remain on as long as motion is detected. When the movement stops, the light remains switched on for a specified back-up time, after which it is switched off.

If motion is detected again during the back-up time, the cycle will start from the beginning. **Due to its high sensitivity, the DRM can act as a presence sensor.** The accuracy of the sensor operation does not depend on the temperature. The detection range, the brightness level that activates the sensor and the time of operation back-up are set using the knobs described later in this manual. The sensor is designed for indoor use.



The power of microwave radiation is relatively low and completely safe for humans and animals. Its value is below 10 mW. In comparison, a microwave oven and a mobile phone radiate with a power of approx. 1000 mW.

## Diagram

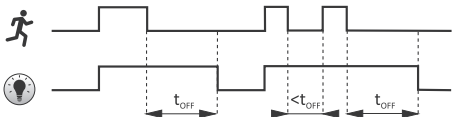

## Settings

### Twilight switch sensitivity (LUX)



Sensitivity of the twilight switch can be adjusted in the range of 2÷2000 lx. Turning the knob towards the "moon" will switch the lighting on later, turning the knob towards the "sun" will switch it on earlier. To keep the sensor active throughout the whole day, turn the knob as far as possible towards the "sun".

### Detection area (SENS)



The detection radius of the sensor can be adjusted from 1 m to 10 m (parameters given for a sensor mounted at a height of 2.5 m). Turning the knob clockwise [max] increases the detection area, turning it counterclockwise [min] decreases the detection area.

### Switch-on time (TIME)



The switch-on time of the receiver can be adjusted in the range from 5 s to 12 min. Turning the knob clockwise [max] increases the switch-on time, turning it counterclockwise [min] decreases the switch-on time.

## Mounting

1. Unscrew the external sensor cover. Unscrew the 2 screws and remove the sensor cover (Fig. 1).
2. Disconnect the power supply.
3. Pass the wires through the rubber grommet in the sensor mounting base.
4. Fasten the base with 2 screws to the ground (Fig. 2).
5. Connect according to the diagram.
6. Set the area of the detection field, the sensitivity of the twilight automatic system and the switching time.
7. Assemble the sensor casing (Fig. 3).



When the power is switched on, the motion detector is inactive for the first 10 seconds.

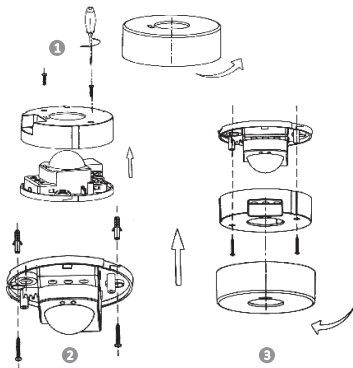

## Wiring diagram

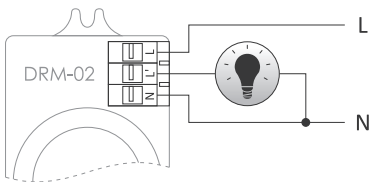

3-terminal connection

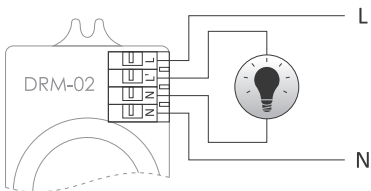





4-terminal connection

## Technical data

power supply	195÷265 V AC
maximum load current (AC-1)	5 A
frequency of microwaves radiation	5.8 GHz
radiation power	10 mW
detection field	360°
detection radius (adjustable)	
for h= 2.5 m	1÷10 m
activation threshold (adjustable)	2÷2000 lx
switching time (adjustable)	5 s÷12 min.
activation delay	1 s
power consumption	0.9 W
terminal	1.0 mm <sup>2</sup> screw terminals
tightening torque	0.25 Nm
working temperature	-25÷50°C
dimensions	∅103, h= 44 mm
mounting	surface
mounting height	2÷6 m
ingress protection	IP20

## Power table

				
tungsten	halogen	fluorescent	energy-saving	LED
1000 W	700 W	100 W	100 W	100 W

The above data are indicative and will heavily depend on the design of a specific receiver (that is especially important for LED bulbs, energy-saving lamps, electronic transformers and pulse power supply units), switching frequency and operating conditions.

For more information visit: [www.fif.com.pl](http://www.fif.com.pl).

## Warranty

The F&F products are covered by a warranty of the 24 months from the date of purchase. Effective only with proof of purchase. Contact your dealer or directly with us.

## CE declaration

F&F Filipowski L.P. declares that the device is in conformity with the essential requirements of The Directive 2014/53/EU of the European Parliament and of the Council of 16 April 2014 on the harmonisation of the laws of the Member States relating to the making available on the market of radio equipment and repealing Directive 1999/5/EC.

The CE Declaration of Conformity, along with the references to the standards in relation to which conformity is declared, can be found at [www.fif.com.pl](http://www.fif.com.pl) on the product page.

## Compliance with standards

PN-EN 62368-1:2015-03

PN-EN 62479:2011

PN-ETSI EN 301 489-1 V2.1.1:2017-08

PN-ETSI EN 300 489-3 V1.6.1:2014-03

PN-ETSI EN 300 440-2 v.2.1.1: 2017-10

**«F&F»<sup>®</sup>**